

# *Owner's Guide and Installation Instructions*



## *Air Sourced 310 Heat Pump Water Heater*



*Install a Rheem*

*This water heater must be installed and serviced by a qualified person.  
Please leave this guide with the householder.*

---

**PATENTS**

This water heater may be protected by one or more patents or registered designs in the name of Rheem Australia Pty Ltd.

**TRADE MARKS**

® Registered trademark of Rheem Australia Pty Ltd.  
™ Trademark of Rheem Australia Pty Ltd.

**Note:** Every care has been taken to ensure accuracy in preparation of this publication. No liability can be accepted for any consequences, which may arise as a result of its application.

---

# CONTENTS

---

**HOUSEHOLDER – We recommend you read pages 4 to 14.**  
The other pages are intended for the installer but may be of interest.

<b>About Your Water Heater .....</b>	<b>4</b>
<b>Regular Care .....</b>	<b>8</b>
<b>Water Supplies.....</b>	<b>10</b>
<b>Save A Service Call .....</b>	<b>12</b>
<b>Installation.....</b>	<b>15</b>
<b>Heat Pump And Tank Assembly .....</b>	<b>22</b>
<b>Connections – Plumbing .....</b>	<b>29</b>
<b>Connections – Electrical.....</b>	<b>31</b>
<b>Multiple Installations .....</b>	<b>33</b>
<b>Commissioning.....</b>	<b>36</b>
<b>Draining The Water Heater .....</b>	<b>37</b>
<b>Warranty .....</b>	<b>39</b>

---

## ABOUT YOUR WATER HEATER

---

### WATER HEATER APPLICATION

This water heater is designed for use in a single family domestic dwelling for the purpose of heating potable water. Its use in an application other than this may shorten its life.

### MODEL TYPE

Your Rheem® air sourced heat pump water heater is designed for outdoor installation only. The model you have chosen is a 551 series model. The 551 310 model heat pump water heater is recommended for connection to a minimum 16 hour per day power supply.

A Rheem heat pump water heater consumes less energy than an electric water heater. The impact on an electricity account will depend on the tariff arrangement of the water heater replaced and where you live. Contact your energy provider for more information on tariff arrangements and cost comparisons.

The Rheem air sourced heat pump water heater has a Rheemglas® vitreous enamel lined steel cylinder. The water heater's evaporator absorbs heat from the surrounding air and transfers this heat into the water.

When hot water is drawn off and cold water enters the tank, the thermostat activates a fan, a compressor and a circulator. The fan draws outside air in through the air inlet louvres at the top of the water heater and the pump circulates water from the bottom of the storage tank through a heat exchanger. Heat is absorbed from the air by an evaporator and transferred into the water through the heat exchanger. The resulting cold air is then discharged through the air outlet louvres back to atmosphere and the heated water is circulated back into the top of the storage tank. This process continues while ever heating is required until the water in the storage tank reaches a temperature of 60°C.

Even on cloudy or cold days, heat is drawn from the surrounding air. The heat pump will operate when the ambient air temperature is 5°C or higher. The booster heating unit will operate when the ambient air temperature falls below 5°C, if heating is required. The efficiency of the water heater increases as the surrounding ambient air temperature increases.

Automatic safety controls are fitted to the water heater to provide safe and efficient operation.

### ELECTRIC BOOSTING

Ice may begin to form on the evaporator reducing the heat pump efficiency, when the ambient air temperature falls below 7°C and the heat pump has been operating for an extended period. At ambient air temperatures below 5°C, the water heater deactivates the heat pump operation and switches to the booster heating unit. During this period the evaporator will defrost if necessary.

The boost capacity in this mode is 220 litres. The water inside the tank will be heated to a temperature of 60°C by the electric booster heating unit if heating is required. The temperature setting of the sensor controlling the booster heating unit is not adjustable and is set at 60°C.

### MAINS PRESSURE

The water heater is designed to operate at mains pressure by connecting directly to the mains water supply. If the mains supply pressure in your area exceeds that [shown on page 16](#), a pressure limiting valve must be fitted. The supply pressure should be greater than 350 kPa for true mains pressure operation to be achieved. A minimum water supply pressure of 200 kPa is required to enable the heat pump circulator and heat pump system to operate effectively.

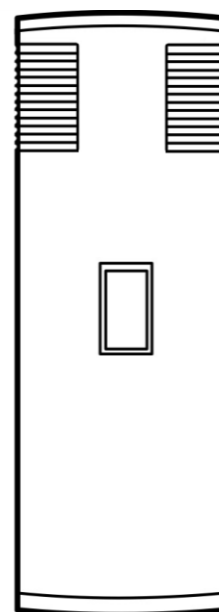

**HOW HOT SHOULD THE WATER BE?**

The system controls (compressor, evaporator and fan) will operate until a water temperature of approximately 60°C is reached. If the ambient air temperature is outside of the heat pump's operating range, the water temperature is boosted automatically to 60°C by the electric booster heating unit, if heating is required.

To meet the requirements of the National Plumbing Standard the temperature of the stored water must not be below 60°C.

**HOTTER WATER INCREASES THE RISK OF SCALD INJURY**

This water heater can deliver water at temperatures which can cause scalding. Check the water temperature before use, such as when entering a shower or filling a bath or basin, to ensure it is suitable for the application and will not cause scald injury.

We recommend and it may also be required by regulations that an approved temperature limiting device be fitted into the hot water pipe work to the bathroom and ensuite when this water heater is installed. This will keep the water temperature below 50°C at the bathroom and ensuite. The risk of scald injury will be reduced and still allow hotter water to the kitchen and laundry.

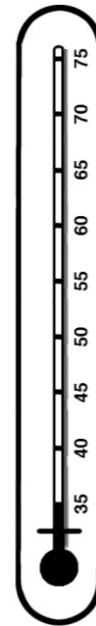

typical maximum temperature from heat pump operation; booster temperature setting; minimum recommended stored water temperature

maximum recommended supply temperature to bathrooms and ensuites

**TEMPERATURE ADJUSTMENT**

The thermostats controlling the heat pump and the booster heating unit are factory set and not adjustable.

**⚠ WARNING**

This water heater is only intended to be operated by persons who have the experience or the knowledge and the capabilities to do so. This water heater is not intended to be operated by persons with reduced physical, sensory or mental capabilities i.e. the infirm, or by children. Children should be supervised to ensure they do not interfere with the water heater.

This water heater uses 240 V AC electrical power for operation of the control systems and the electrically operated components. The removal of the access cover(s) will expose 240 volt wiring. They must only be removed by a qualified person.

- Do not use **aerosols, stain removers and household chemicals** near the water heater whilst it is working. Gases from some aerosol sprays, stain removers and household chemicals are corrosive to the materials used in the heat pump system.
- Do not store swimming pool chemicals, household cleaners, etc., near the water heater.
- Ensure the air inlet and outlet louvres and air flow are not obstructed in any way at any time.

**SAFETY**

This water heater is supplied with a thermostat, two over-temperature energy cut-outs and a combination temperature pressure relief valve. These devices must not be tampered with or removed. The water heater must not be operated unless each of these devices is fitted and is in working order.

The operation of the over-temperature cut-out on the thermostat indicates a possibly dangerous situation. If the over-temperature cut-out operates, it must not be reset and the water heater must be serviced by a qualified person.

If the electrical supply conduit to the water heater is damaged, it must be replaced by a qualified person in order to avoid a hazard. Phone Rheem Service or their nearest Accredited Service Agent to arrange for an inspection.

**⚠ Warning:** For continued safety of this water heater it must be installed, operated and maintained in accordance with the Owner's Guide and Installation Instructions.

**The Rheem warranty may not cover faults if relief valves or other safety devices are tampered with or if the installation is not in accordance with these instructions.**

### TIMER CONTROL

A timer can be installed in the electrical circuit to the water heater. The timer must be weatherproof if it is installed outdoors.

It may be desirable for the water heater not to operate between certain hours, such as during the peak period when connected to a Time of Use electricity supply due to a more expensive tariff rate applying. A timer will affect the operating times of both the heat pump circuit and the booster heating unit.

**Note:** The 551 310 model heat pump water heater is recommended for connection to a minimum 16 hour per day power supply.

### TO TURN OFF THE WATER HEATER

If you plan to be away from home for only a few nights, we suggest you leave the water heater switched on. If it is necessary to turn off the water heater:

- Switch off the electrical supply at the isolating switch to the water heater.
- Close the cold water isolation valve at the inlet to the water heater.

### TO TURN ON THE WATER HEATER

- Open the cold water isolation valve fully on the cold water line to the water heater.
- Switch on the electrical supply at the isolating switch to the water heater.

The heat pump may take up to 30 seconds to commence operating when the power supply is switched on. The heat pump will only operate when the water in the storage tank requires heating, the heat pump compressor is cool and power is available at the water heater. If the ambient air temperature is below the minimum operating temperature of 5°C and the system calls for heating, the booster heating unit will operate instead.

When the heat pump is operating, the system may switch to the booster heating unit if it detects that the ambient air temperature is below the minimum operating temperature of 5°C. It may also switch back to heat pump operation from the booster heating unit if it detects the ambient air temperature has moved back to within the heat pump's operating temperature range.

**Note:** The heat pump may not turn on after having just completed a heating cycle and more hot water is drawn from the water heater. The heat pump will wait until the compressor has cooled down and the conditions for start up are favourable, in order to protect the compressor from damage. This may take up to 20 minutes from the last heating cycle.

### GOING ON HOLIDAYS

If you plan to be away from home for a few nights, we suggest you leave the water heater switched on. If you plan to be away for a longer period, conserve energy by switching off the isolating switch to the water heater (refer to ["To Turn Off The Water Heater"](#) on page 6).

### PRECAUTIONS

Where damage to property can occur in the event of the water heater leaking, the water heater must be installed in a safe tray. Construction, installation and draining of a safe tray must comply with AS/NZS 3500.4 and all local codes and regulatory authority requirements.

The water heater must be maintained in accordance with the Owner's Guide and Installation Instructions. Refer to ["Regular Care"](#) on page 8 and to ["Anode Inspection and Replacement"](#) on page 10.

If this water heater is to be used where an uninterrupted hot water supply is necessary for your application or business you should ensure that you have back up redundancy within the hot water system design. This should ensure the continuity of hot water supply in the event that this water heater were to become inoperable for any reason. We recommend you seek advice from your plumber or specifier about your needs and building back up redundancy into your hot water supply system.

### **HOW DO I KNOW IF THE WATER HEATER IS INSTALLED CORRECTLY?**

Installation requirements are [shown on pages 15 to 20](#). The water heater must be installed:

- by a qualified person, and
- in accordance with the installation instructions, and
- in compliance with Standards AS/NZS 3500.4, AS/NZS 3000 and all local codes and regulatory authority requirements.

In New Zealand, the installation must also conform with Clause G12 of the New Zealand Building Code.

### **VICTORIAN CUSTOMERS**

Notice to Victorian Customers from the Victorian Plumbing Industry Commission. This water heater must be installed by a licensed person as required by the Victorian Building Act 1993.

Only a licensed person will give you a Compliance Certificate, showing that the work complies with all the relevant Standards. Only a licensed person will have insurance protecting their workmanship for 6 years. Make sure you use a licensed person to install this water heater and ask for your Compliance Certificate.

### **DOES THE WATER CHEMISTRY AFFECT THE WATER HEATER?**

The water heater is suitable for most public water supplies, however some water chemistries may have detrimental effects on the water heater, its components and fittings. Refer to [“Water Supplies”](#) on page 10.

If you are in a known harsh water area or you are not sure of your water chemistry, have your water checked against the conditions [described on pages 10 to 11](#).

### **HOW LONG WILL THE WATER HEATER LAST?**

The water heater is supported by a manufacturer’s warranty ([refer to page 39](#)). There are a number of factors that will affect the length of service the water heater will provide. These include but are not limited to the water chemistry, the water pressure, the water temperature (inlet and outlet) and the water usage pattern. Refer to [“Precautions”](#) on page 6.

### **ENVIRONMENT**

At the end of the service life of the heat pump water heater and prior to the water heater being disposed of, a person qualified to work with refrigerants must recover the refrigerant from within the sealed system. The refrigerant must not be vented to atmosphere. Phone Rheem Service or their nearest Accredited Service Agent to arrange for an inspection.

---

## REGULAR CARE

---

### MINOR SIX MONTH MAINTENANCE

It is recommended minor maintenance be performed every six months by the dwelling occupant.

The minor maintenance includes:

- Operate the easing lever on the temperature pressure relief valve. It is very important you raise and lower the lever gently. Refer to “[Temperature Pressure Relief Valve](#)” on page 9.

**⚠ Warning:** Exercise care to avoid any splashing of water, as water discharged from the drain line will be hot. Stand clear of the drain line’s point of discharge when operating the valve’s lever.

- Operate the easing lever on the expansion control valve (if fitted). It is very important you raise and lower the lever gently. Refer to “[Expansion Control Valve](#)” on page 9.
- Check the drain line from the safe tray (if one is installed) is not blocked.

### MAJOR FIVE YEAR SERVICE

It is recommended a major five year service be conducted on the water heater. The service must be conducted by a qualified person. Phone Rheem Service or their nearest Accredited Service Agent.

**Note:** The five year service and routine replacement of any components, such as the anode and relief valve(s), are not included in the Rheem warranty. A charge will be made for this work.

The major service includes:

- Replace the temperature pressure relief valve.
- Inspect and flush the expansion control valve (if fitted). If required, replace the valve.
- Inspect and if required, replace the anode.

If the anode is not replaced, it should be replaced within three years of this service (refer to “[Anode Inspection and Replacement](#)” on page 10).

- Check the electric heating unit for excessive calcium build up or corrosion and replace if necessary.
- Check and inspect the heat pump module for operation.
- Visually check the unit for any potential problems.
- Inspect all connections.
- Check the condensate drain.
- Check the drain line from the safe tray (if one is installed) is not blocked.

**Note:** The water heater may need to be drained during this service. After the completion of the service, the water heater will take some time to reheat the water. Depending upon the power supply connection, hot water may not be available until the next day.

### HEAT PUMP SYSTEM

It is recommended the evaporator and refrigeration system is checked every five years. In particularly dusty environments, it may be necessary to have the heat pump system checked and cleaned of dust and residue on a more regular basis.



### TEMPERATURE PRESSURE RELIEF VALVE

This valve is near the top of the water heater and is essential for its safe operation. It is possible for the valve to release a little water through the drain line during each heating period. This occurs as the water is heated and expands by approximately 1/50 of its volume.

Continuous leakage of water from the valve and its drain line may indicate a problem with the water heater (refer to “[Temperature Pressure Relief Valve Running](#)” on page 14).

**⚠ Warning:** Never block the outlet of this valve or its drain line for any reason.

Operate the easing lever on the temperature pressure relief valve once every six months. **It is very important you raise and lower the lever gently.**

**⚠ DANGER:** Failure to do this may result in the water heater cylinder failing, or under certain circumstances, exploding.

**⚠ Warning:** Exercise care to avoid any splashing of water, as water discharged from the drain line will be hot. Stand clear of the drain line’s point of discharge when operating the valve’s lever.

If water does not flow freely from the drain line when the lever is lifted, then the water heater must be checked. Phone Rheem Service or their nearest Accredited Service Agent to arrange for an inspection.

The temperature pressure relief valve should be replaced at intervals not exceeding 5 years, or more frequently in areas where there is a high incidence of water deposits (refer to “[Water Supplies](#)” on page 10).

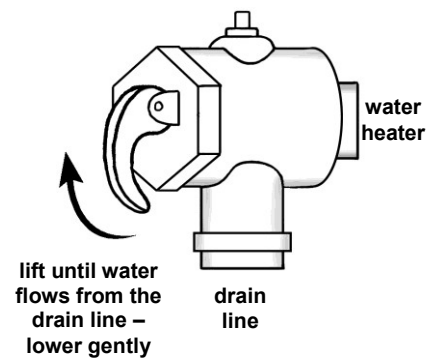
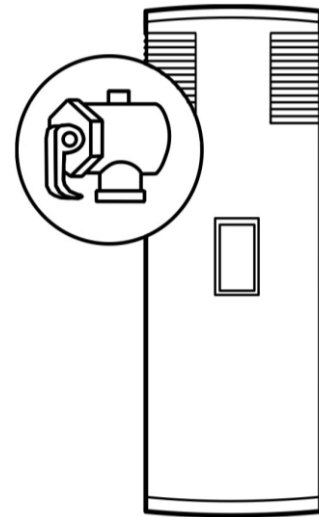

### EXPANSION CONTROL VALVE

In many areas, including South Australia, Western Australia and scaling water areas, an expansion control valve is fitted to the cold water line to the water heater. The expansion control valve may discharge a small quantity of water from its drain line during the heating period instead of the temperature pressure relief valve on the water heater.

Operate the easing lever on the expansion control valve once every six months. **It is very important you raise and lower the lever gently.** The expansion control valve should be checked for performance or replaced at intervals not exceeding 5 years, or more frequently in areas where there is a high incidence of water deposits.

---

## WATER SUPPLIES

---

**This water heater must be installed in accordance with this advice to be covered by the Rheem warranty.**

This water heater is manufactured to suit the water conditions of most public reticulated water supplies. However, there are some known water chemistries which can have detrimental effects on the water heater and its operation and / or life expectancy. If you are unsure of your water chemistry, you may be able to obtain information from your local water supply authority. This water heater should only be connected to a water supply which complies with these guidelines for the Rheem warranty to apply.

### CHANGE OF WATER SUPPLY

The changing or alternating from one water supply to another can have a detrimental effect on the operation and / or life expectation of a number of components in this water heater.

Where there is a changeover from one water supply to another, e.g. a rainwater tank supply, bore water supply, desalinated water supply, public reticulated water supply or water brought in from another supply, then water chemistry information should be sought from the supplier or it should be tested to ensure the water supply meets the requirements given in these guidelines for the Rheem warranty to apply.

### ANODE

The vitreous enamel lined cylinder of the water heater is only covered by the Rheem warranty when the total dissolved solids (TDS) content in the water is less than 2500 mg/L and when the correct colour coded anode is used. If an incorrect colour coded anode is used in the water heater, any resultant faults will not be covered by the Rheem warranty. In addition, the use of an incorrect colour coded anode may shorten the life of the storage tank.

The correct colour coded anode is as shown in the following table:

Total Dissolved Solids	Anode colour code
0 – 40 mg/L	Green
40 – 150 mg/L	Green or Black
150 – 400 mg/L	Black
400 – 600 mg/L	Black or Blue
600 – 2500 mg/L	Blue
2500 mg/L +	Blue (no cylinder warranty)

The changing of anodes must be carried out by a qualified person.

**Note:** Some water analysis reports may state the conductivity of the water rather than the level of total dissolved solids. Conductivity, measured in microsiemens per centimetre ( $\mu\text{S} / \text{cm}$ ), is directly proportional to the TDS content of the water. TDS, in mg / L, is approximately 70% of the conductivity in  $\mu\text{S} / \text{cm}$ .

### ANODE INSPECTION AND REPLACEMENT

The anode installed in your water heater will slowly dissipate whilst protecting the cylinder. The life of the cylinder may be extended by replacing the anode.

If the anode is not replaced during a five year service (refer to “Major Five Year Service” on page 8) then the maximum time after installation when the anode should be replaced for this water heater is 8 years.

For water supplies which are either softened, desalinated or where the water supply may alternate between a water tank and a reticulated public supply or another supply, it is recommended the anode be replaced within 5 years of installation.

**CAUTION**

If the water supply has a TDS greater than 150 mg/L and a green anode has not been changed to a black anode, or if the TDS is greater than 600 mg/L and the anode has not been changed to a blue anode, there is the possibility the anode may become overactive and hydrogen gas could accumulate in the top of the water heater during long periods of no use. In areas where this is likely to occur, the installer should instruct the householder on how to dissipate the gas safely.

If, under these conditions, the water heater has not been used for two or more weeks the following procedure should be carried out before using any electrical appliances (automatic washing machines and dishwashers) which are connected to the hot water supply.

The hydrogen, which is highly flammable, should be vented safely by opening a hot tap and allowing the water to flow. There should be no smoking or naked flame near the tap whilst it is turned on. Any hydrogen gas will be dissipated. This is indicated by an unusual spurting of the water from the tap. Once the water runs freely, any hydrogen in the system will have been released.

**SATURATION INDEX**

The saturation index (SI) is used as a measure of the water's corrosive or scaling properties.

Where the saturation index is less than  $-1.0$ , the water is very corrosive and the Rheem warranty does not apply to the water heater. In a corrosive water supply, the water can attack copper parts and cause them to fail.

Where the saturation index exceeds  $+0.40$ , the water is very scaling and the Rheem warranty does not apply to the water heater.

Water which is scaling may be treated with a water softening device to reduce the saturation index of the water.

**CHLORIDE AND PH**

Where the chloride level exceeds 250 mg/L the Rheem warranty does not apply to the water heater. In a high chloride water supply, the water can corrode stainless steel parts and cause them to fail.

Where the pH is less than 6.0 the Rheem warranty does not apply to the water heater. pH is a measure of whether the water is alkaline or acid. In an acidic water supply, the water can attack stainless steel parts and cause them to fail.

Water with a pH less than 6.0 may be treated to raise the pH. The water supply from a rainwater tank in a metropolitan area is likely to be corrosive due to the dissolution of atmospheric contaminants.

**SUMMARY OF WATER CHEMISTRY ADVICE AFFECTING WARRANTY**

The water heater is not suitable for certain water chemistries. Those chemistries are listed below. If the water heater is connected at any time to a water supply with the following water chemistry, the Rheem warranty will not cover any resultant faults:

<b>Water Chemistry</b>	<b>Component</b>
Total Dissolved Solids (TDS) > 2500 mg/L	water heater cylinder
Total Dissolved Solids (TDS) not suitable for anode type	water heater cylinder
Saturation Index (SI) < -1.0	water heater
Saturation Index (SI) > +0.4	water heater
Chloride > 250 mg/L	water heater
pH < 6.0	water heater

---

## SAVE A SERVICE CALL

---

Check the items below before making a service call. You will be charged for attending to any condition or fault that is not related to manufacture or failure of a part.

### NOT ENOUGH HOT WATER (OR NO HOT WATER)

- **Is the electricity switched on?**

Inspect the isolating switch marked “HOT WATER” or “WATER HEATER” at the switchboard and the isolating switch (if one is installed) at the water heater and ensure they are turned on.

Check the fuse marked “HOT WATER” or “WATER HEATER” at the switchboard.

- **Is a timer installed?**

If a timer has been installed, ensure sufficient time has been allowed to reheat the storage tank.

- **Are you using more hot water than you think?**

Is one outlet (especially the shower) using more hot water than you think?

Very often it is not realised the amount of hot water used, particularly when showering. Carefully review the family's hot water usage. As you have installed an energy saving appliance, energy saving should also be practised in the home.

Adjust your water usage pattern to take advantage of maximum energy gains. Have your plumber install a flow control valve to each shower outlet to reduce water usage.

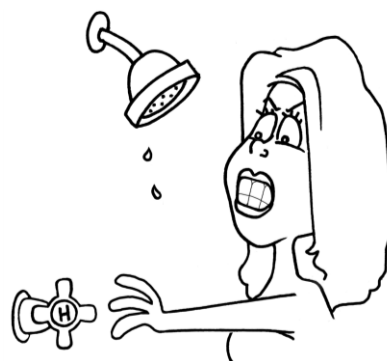

- **Heat pump fault**

Has the heat pump developed a fault?

The heat pump will not operate and the water heater will switch to backup heating mode. The boost capacity of the heating unit in backup heating mode is 110 litres.

Refer to “[Heat Pump Is Not Operating](#)” on page 13.

- **Temperature pressure relief valve running**

Is the relief valve discharging too much water?

Refer to “[Temperature Pressure Relief Valve Running](#)” on page 14.

- **Water heater size**

Do you have the correct size water heater for your requirements?

The sizing guide in the sales literature and on the Rheem website ([www.rheem.com.au](http://www.rheem.com.au)) suggests average sizes that may be needed.

### WATER NOT HOT ENOUGH

You may find that due to heavy hot water usage the water temperature may be lower than normally expected, due to insufficient heating time being allowed. You will need to carefully plan your use of the hot water on such occasions.

### WATER TOO HOT

The water heater during heat pump operation and booster heating mode will heat the water to a temperature of 60°C. If a heat pump component has developed a fault condition, the heat pump will not operate and the water heater will switch to backup heating mode to ensure a supply of hot water.

In backup heating mode, the booster heating unit and its controlling thermostat will operate if heating of the water is required, regardless of the ambient air temperature. The water heater, during backup heating mode will heat the water to a temperature of 70°C. The boost capacity of the heating unit in backup heating mode is 110 litres.

Phone Rheem Service or their nearest Accredited Service Agent to arrange for an inspection.

---

## HEAT PUMP IS NOT OPERATING

- **Time controlled power supply**

If the water heater is connected to a time controlled power supply, then during periods of no power supply at the water heater the heat pump and booster heating unit will not operate.

This is not a fault condition, but a result of no power being available to operate the water heater.

- **Heat pump operating range**

The heat pump will not operate for extended periods when the ambient air temperature is outside the heat pump's operating range. The heat pump will operate when the ambient air temperature is 5°C or higher. The booster heating unit will operate when the ambient air temperature falls below 5°C, if heating is required.

The boost capacity of the booster heating unit in booster heating mode is 220 litres and the water will be heated to 60°C during these periods.

Heating of the water by the heat pump will occur when the ambient air temperature returns to within the heat pump's operating range.

- **Thermal cut out activated**

Has the thermal cut out for the heat pump compressor activated?

The refrigeration circuit is protected by a thermal sensor. This will activate a thermal cut out in the event of thermal surges or excessive heat in the refrigeration system.

If the thermal cut out has activated, the heat pump will not operate. The water heater will switch to booster heating mode to ensure a supply of hot water. If heating of the water is required, the booster heating unit will operate regardless of the ambient air temperature. In booster heating mode, the boost capacity of the heating unit is 220 litres and the water will be heated to 60°C.

The thermal cut out will automatically reset itself when the compressor cools down.

To check whether there may be a problem, open a hot tap and allow to run for ten to fifteen minutes. The heat pump, if working properly, will activate and continue operating to heat the water. Close the hot tap when the heat pump begins to operate.

However, if the heat pump deactivates within five minutes, there may be a problem. Phone Rheem Service or their nearest Accredited Service Agent to arrange for an inspection.

- **Heat pump fault**

Has the heat pump developed a fault?

If the heat pump has developed a fault condition, the heat pump will not operate and the water heater will switch to backup heating mode to ensure a supply of hot water.

In backup heating mode, the booster heating unit and its controlling thermostat will operate if heating of the water is required, regardless of the ambient air temperature. The water heater, during backup heating mode will heat the water to a temperature of 70°C. The boost capacity of the heating unit in backup heating mode is 110 litres.

Phone Rheem Service or their nearest Accredited Service Agent to arrange for an inspection.

## EXPANSION CONTROL VALVE RUNNING

If an expansion control valve is fitted in the cold water line to the water heater (refer to page 29) it may discharge a small quantity of water instead of the temperature pressure relief valve on the water heater. The benefit is that energy is conserved as the discharged water is cooler.

## TEMPERATURE PRESSURE RELIEF VALVE RUNNING

- **Normal Operation**

It is normal and desirable this valve allows a small quantity of water to escape during the heating cycle. However, if it discharges more than a bucket full of water in 24 hours, there may be another problem.

- **Continuous dribble**

Try gently raising the easing lever on the relief valve for a few seconds (refer to “[Temperature Pressure Relief Valve](#)” on page 9). This may dislodge a small particle of foreign matter and clear the fault. Release the lever gently.

- **Steady flows for long periods (often at night)**

This may indicate the mains water pressure sometimes rises above the designed pressure of the water heater. Ask your installing plumber to fit a pressure limiting valve.

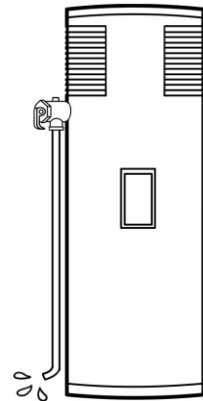

**⚠ Warning:** Never replace the relief valve with one of a higher pressure rating.

- **Heavy flows of hot water until the water heater is cold - then stops until water reheats**

The water heater **must** be switched off at the isolating switch or switchboard. Phone Rheem Service or their nearest Accredited Service Agent to arrange for an inspection.

## HIGHER THAN EXPECTED ELECTRICITY BILLS

With the installation of your new air sourced heat pump water heater, maximum electrical energy savings can be achieved. Should you at any time, feel your electricity account is higher than expected, we suggest you check the following points:

- Is the water heater operating in backup heating mode?

If there is a fault condition with the heat pump system, the water heater will default to backup heating mode to ensure a supply of hot water. If the water is being heated to a temperature of 70°C, this will indicate there may be a fault with the system.

Refer to “[Heat Pump Is Not Operating](#)” on page 13.

- Is the relief valve running excessively?

Refer to “[Temperature Pressure Relief Valve Running](#)” on page 14.

- Is one outlet (especially the shower) using more hot water than you think?

Refer to “[Not Enough Hot Water](#)” on page 12.

- Is there a leaking hot water pipe, dripping hot water tap, etc?

Even a small leak will waste a surprising quantity of hot water and energy. Replace faulty tap washers, and have your plumber rectify any leaking pipe work.

- Has there been an increase in hot water usage?

An increase in hot water usage will result in an increase in heat pump operation.

- Has your water heating tariff rate been increased by your electricity retailer since your previous account?

- Is the heat pump water heater on the same tariff as the water heater replaced?

The impact on an electricity account will depend upon the tariff arrangement of the water heater replaced and where you live. Contact your energy provider for more information on tariff arrangements and cost comparisons.

- Prolonged periods of use when the ambient air temperature is outside of the heat pump’s operating range will increase the amount of boosting and increase running costs.

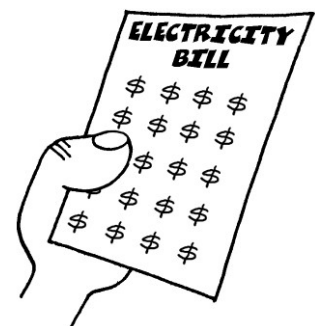

**IF YOU HAVE CHECKED ALL THE FOREGOING AND STILL BELIEVE YOU NEED ASSISTANCE, PHONE RHEEM SERVICE OR THEIR NEAREST ACCREDITED SERVICE AGENT.**

---

# INSTALLATION

---

**THIS WATER HEATER IS FOR OUTDOOR INSTALLATION ONLY.  
THIS WATER HEATER IS NOT SUITABLE FOR POOL HEATING.**

## INSTALLATION STANDARDS

The water heater must be installed:

- by a qualified person, and
- in accordance with the installation instructions, and
- in compliance with Standards AS/NZS 3500.4, AS/NZS 3000 and all local codes and regulatory authority requirements.

In New Zealand, the installation must also conform with Clause G12 of the New Zealand Building Code.

## Victorian Installers

Notice to Victorian Installers from the Victorian Plumbing Industry Commission if this solar water heater is installed in a new Class 1 dwelling in the State of Victoria. The system model number is to be recorded on the Certificate of Compliance. It is also a requirement to provide the householder with permanent documentation recording the system model number exactly as it is shown in the 'List of systems capable of complying with the regulations' published by Sustainability Victoria (see [www.sustainability.vic.gov.au](http://www.sustainability.vic.gov.au)). This documentation may be in the form of an indelible label adhered to the solar storage tank, or other suitable form placed in an accessible location, such as the meter box, for later inspection.

## WATER HEATER APPLICATION

This water heater is designed for use in a single family domestic dwelling for the purpose of heating potable water. Its use in an application other than this may shorten its life.

If this water heater is to be used where an uninterrupted hot water supply is necessary for the application or business, then there should be redundancy within the hot water system design. This should ensure the continuity of hot water supply in the event that this water heater was to become inoperable for any reason. We recommend you provide advice to the system owner about their needs and building backup redundancy into the hot water supply system.

The 551 310 model heat pump water heater is recommended for connection to a minimum 16 hour per day power supply.

A Rheem heat pump water heater consumes less energy than an electric water heater. The impact on an electricity account will depend on the tariff arrangement of the water heater replaced and the installation location. Contact the energy provider for more information on tariff arrangements and cost comparisons.

## STORAGE TANK AND HEAT PUMP MODULE

The heat pump water heater is made of two main components, the storage tank and the heat pump module. For transport and handling (weight) purposes both items are shipped separately and designed to be assembled at the installation site. The water heater must not be operated until both components are assembled. Refer to "[Heat Pump and Tank Assembly](#)" on page 22.

Take care when handling the heat pump module. The jacket of the heat pump module needs to be handled gently so as not to cause damage.

**Do not tilt the heat pump module or the heat pump and storage tank assembly more than 45° from the vertical.** This will unsettle the refrigerant gas and compressor lubricating oil. If the heat pump module or heat pump and storage tank assembly has been tilted more than 45° from the vertical during handling, it will need one hour to settle before the power to the water heater can be switched on, otherwise damage to the compressor may result.

The heat pump module and storage tank can be assembled off site if required and then transported to the installation site. Care must be taken during transportation and handling as the assembly will be top heavy.

All packaging materials must be removed from the water heater prior to its installation. This includes the removal of the cardboard base of the carton from the underside of the water heater.

**WATER HEATER LOCATION**

The water heater is suitable for outdoor installation only. The water heater should be installed close to the most frequently used outlet and its position chosen with noise, safety and service in mind. Make sure people (particularly children) will not accidentally touch the air inlet and outlet louvres and that they are clear of obstructions and shrubbery.

It is advisable to install the water heater away from bedroom or living room windows as the system controls can generate a level of noise whilst they are operating. Consider the location in relation to neighbours' bedrooms and living room windows.

Clearance must be allowed for servicing of the water heater. The water heater must be accessible without the use of a ladder or scaffold. Make sure the temperature pressure relief valve lever is accessible and the top and front cover, air inlet and outlet louvres, system controls and thermostat can be removed for service.

You must be able to read the information on the rating plate. If possible leave headroom of one water heater height so the anode can be inspected or replaced. Remember you may have to remove the entire water heater later for servicing.

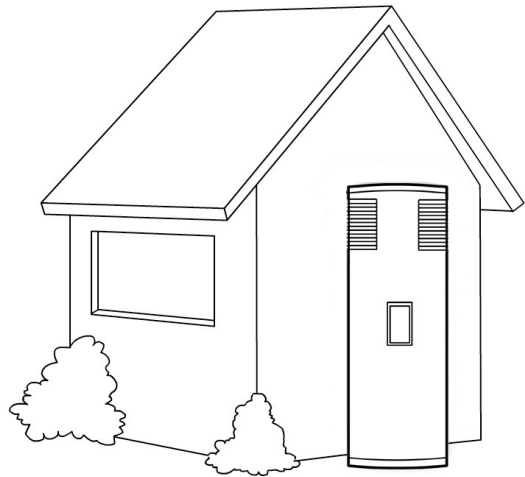

It is recommended the heat pump water heater be installed at ground or floor level and must stand vertically upright, supported by a level slab or solid base. The base of the water heater is made of corrosion resistant material, and it may be placed directly in contact with the supporting surface. It is not necessary to allow for free air circulation under the base of the water heater.

**Note:** The water heater should not be placed in direct contact with a concrete surface that is less than two months old and not fully cured as this may attack the metal coating of the water heater base. A moisture barrier should be used between the two surfaces in this instance.

The water heater must be installed with a clearance of at least 100 mm from a wall. A clearance of at least 300 mm is required perpendicular from both the air inlet and outlet louvres to any wall or obstruction. Refer to the [dimensions diagram](#) on page 21.

The water heater must not be installed in an area with a corrosive atmosphere where chemicals are stored or where aerosol propellants are released. Remember the air may be safe to breathe, but the chemicals may attack the materials used in the heat pump system.

**SAFE TRAY**

Where damage to property can occur in the event of the water heater leaking, the water heater must be installed in a safe tray. Construction, installation and draining of a safe tray must comply with AS/NZS 3500.4 and all local codes and regulatory authority requirements.

**MAINS WATER SUPPLY**

Where the mains water supply pressure exceeds that shown in the table below, an approved pressure limiting valve is required and should be fitted as shown in the installation diagram ([refer to diagram on page 29](#)).

Model	310
Relief valve setting	1000 kPa
Expansion control valve setting *	850 kPa
Max. mains supply pressure	
With expansion control valve	680 kPa
Without expansion control valve	800 kPa
Min. mains supply pressure	200 kPa

\* Expansion control valve not supplied with the water heater.

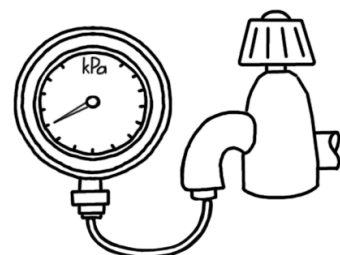



**TANK WATER SUPPLY**

If the water heater is supplied with water from a tank supply and a minimum water supply pressure of 200 kPa at the water heater cannot be achieved, then a pressure pump system must be installed to allow the heat pump circulator to operate and avoid air locks in the circuit. Care must be taken to avoid air locks. The cold water line from the supply tank should be adequately sized and fitted with a full flow gate valve or ball valve.

**PURGING AIR FROM THE SYSTEM**

The water heater system must be purged of air prior to operation, using the air bleed valve supplied on the heat pump module. Failure to bleed the air out of the pipe work within the heat pump module will result in non-operation of the circulator and failure of the heat pump to operate due to overheating.

**HOT WATER DELIVERY**

This water heater can deliver water at temperatures which can cause scalding.

It is necessary and we recommend that a temperature limiting device be fitted between the water heater and the hot water outlets in any ablution area such as a bathroom or ensuite, to reduce the risk of scalding. The installing plumber may have a legal obligation to ensure the installation of this water heater meets the delivery water temperature requirements of AS/NZS 3500.4 so that scalding water temperatures are not delivered to a bathroom, ensuite or other ablution area.

The temperature limiting device used with a heat pump water heater should have a specified 'minimum temperature differential' between the hot water inlet and the tempered water outlet of no greater than 10°C. Refer to the specifications of the temperature limiting device.

Where a temperature limiting device is installed adjacent to the water heater, the cold water line to the temperature limiting device can be branched off the cold water line either before or after the isolation valve, pressure limiting valve and non return valve to the water heater. If an expansion control valve is required, it must always be installed after the non return valve and be the last valve prior to the water heater.

If a pressure limiting valve is installed on the cold water line to the water heater and the cold water line to a temperature limiting device branches off before this valve or from another cold water line in the premises, then a pressure limiting valve of an equal pressure setting may be required prior to the temperature limiting device.

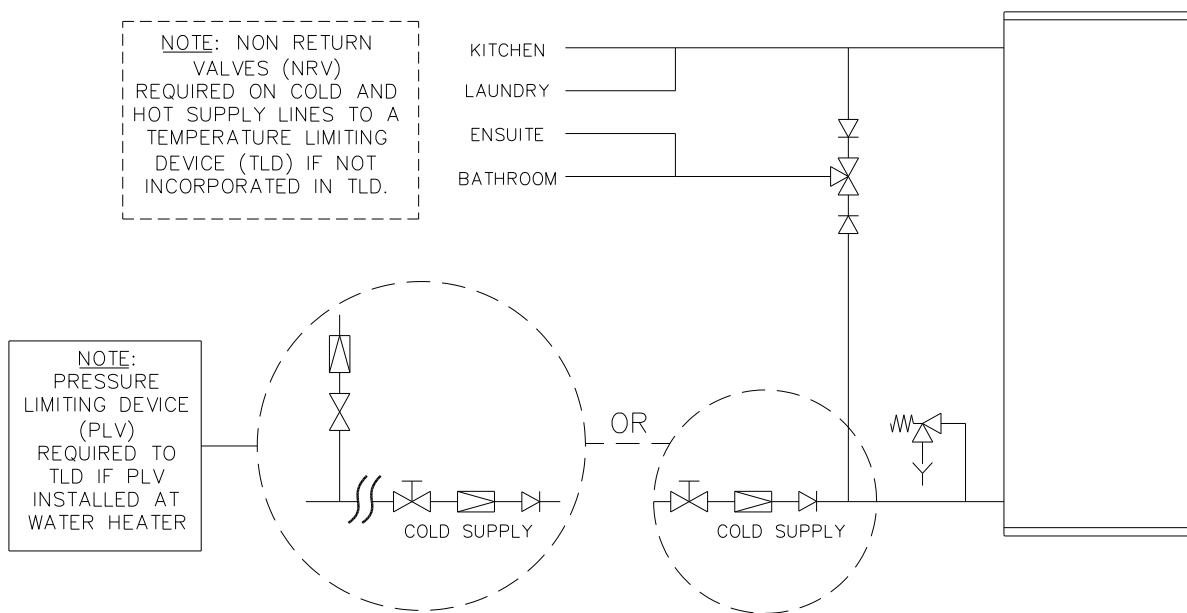

**Two Temperature Zones Using a Temperature Limiting Device**

**CIRCULATED HOT WATER FLOW AND RETURN SYSTEM**

A 551 310 model heat pump water heater should not be installed as part of a circulated hot water flow and return system in a building.

If a circulated flow and return system is required, it is necessary to bypass the heat pump water heater and install a secondary water heater connected to the hot water flow and return line and supplied from the heat pump water heater. The secondary water heater must be a storage water heater able to provide a hot water outlet temperature of at least 60°C. **Note:** The thermostat must always be set to at least 60°C. Refer to the [diagram on page 18](#).

**Temperature Limiting Device**

A temperature limiting device cannot be installed in circulated hot water flow and return pipe work. The tempered water from a temperature limiting device cannot be circulated. Where a circulated hot water flow and return system is required in a building, a temperature limiting device can only be installed on a dead leg, branching off the circulated hot water flow and return pipe.

If circulated tempered water were to be returned back to the water heater, depending on the location of the return line connection on the water supply line to the water heater, then either:

- water will be supplied to the cold water inlet of the temperature limiting device at a temperature exceeding the maximum recommended water supply temperature, or
- when the hot taps are closed no water will be supplied to the cold water inlet of the temperature limiting device whilst hot water will continue to be supplied to the hot water inlet of the temperature limiting device.

These conditions may result in either water at a temperature exceeding the requirements of AS/NZS 3500.4 being delivered to the hot water outlets in the ablution areas, or the device closing completely and not delivering water at all, or the device failing. Under either condition, the operation and performance of the device cannot be guaranteed.

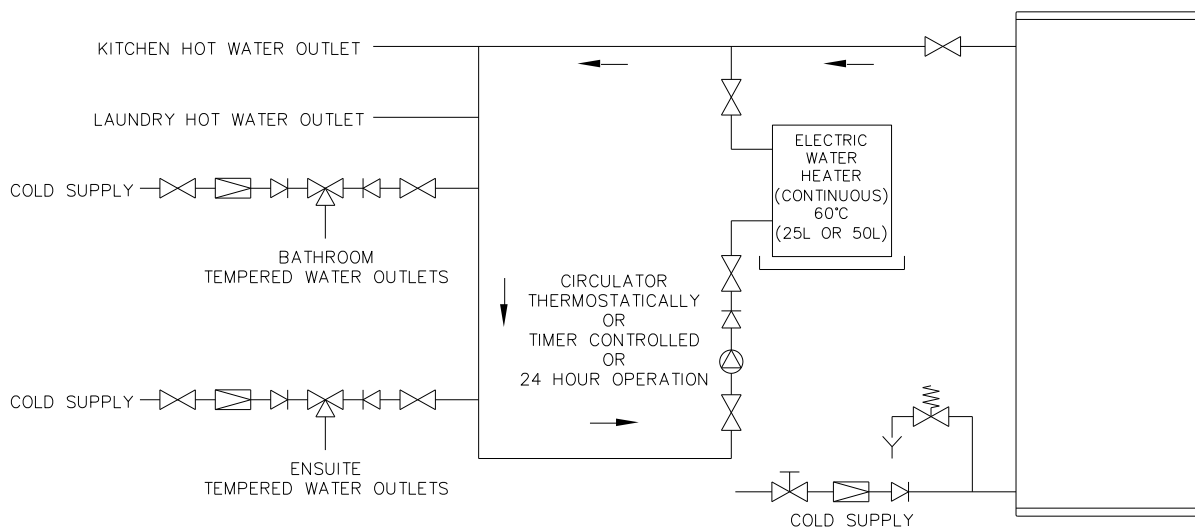

**NOTE:** A PLV IS REQUIRED TO BE INSTALLED ON THE COLD SUPPLY LINE TO THE TEMPERING VALVE IF A PLV IS INSTALLED ON THE COLD SUPPLY LINE TO THE WATER HEATER.

**Circulated Hot Water Flow and Return System – Heat Pump Water Heater**

**REDUCING HEAT LOSSES**

The cold water line to and the hot water line from the water heater must be insulated in accordance with the requirements of AS/NZS 3500.4. The insulation must be weatherproof and UV resistant if exposed.

**ANODE TYPES**

The vitreous enamel lined cylinder of the water heater is only covered by the Rheem warranty when the total dissolved solids (TDS) content in the water is less than 2500 mg/L and when the correct colour coded anode is used. If an incorrect colour coded anode is used in the water heater, any resultant faults will not be covered by the Rheem warranty. In addition, the use of an incorrect colour coded anode may shorten the life of the storage tank. The black anode is typically fitted as standard (refer to “Anode” on page 10).

If an incorrect anode is used, there is also the possibility the anode may become overactive and hydrogen gas could accumulate in the top of the water heater during long periods of no use. In areas where this is likely to occur, the installer should instruct the householder on how to dissipate the gas safely (refer to “Caution” on page 11).

**SADDLING - PIPE WORK**

To prevent damage to the cylinder when attaching pipe clips or saddles to the water heater jacket, we recommend the use of self-drilling screws with a maximum length of 13 mm. Should pre drilling be required, extreme caution must be observed when penetrating the jacket of the water heater.

**Note: If the cylinder is damaged as a result of attaching pipe clips or saddles to the jacket, any resultant faults will not be covered by the Rheem warranty.**

**TYPICAL INSTALLATION – OUTDOOR LOCATION**

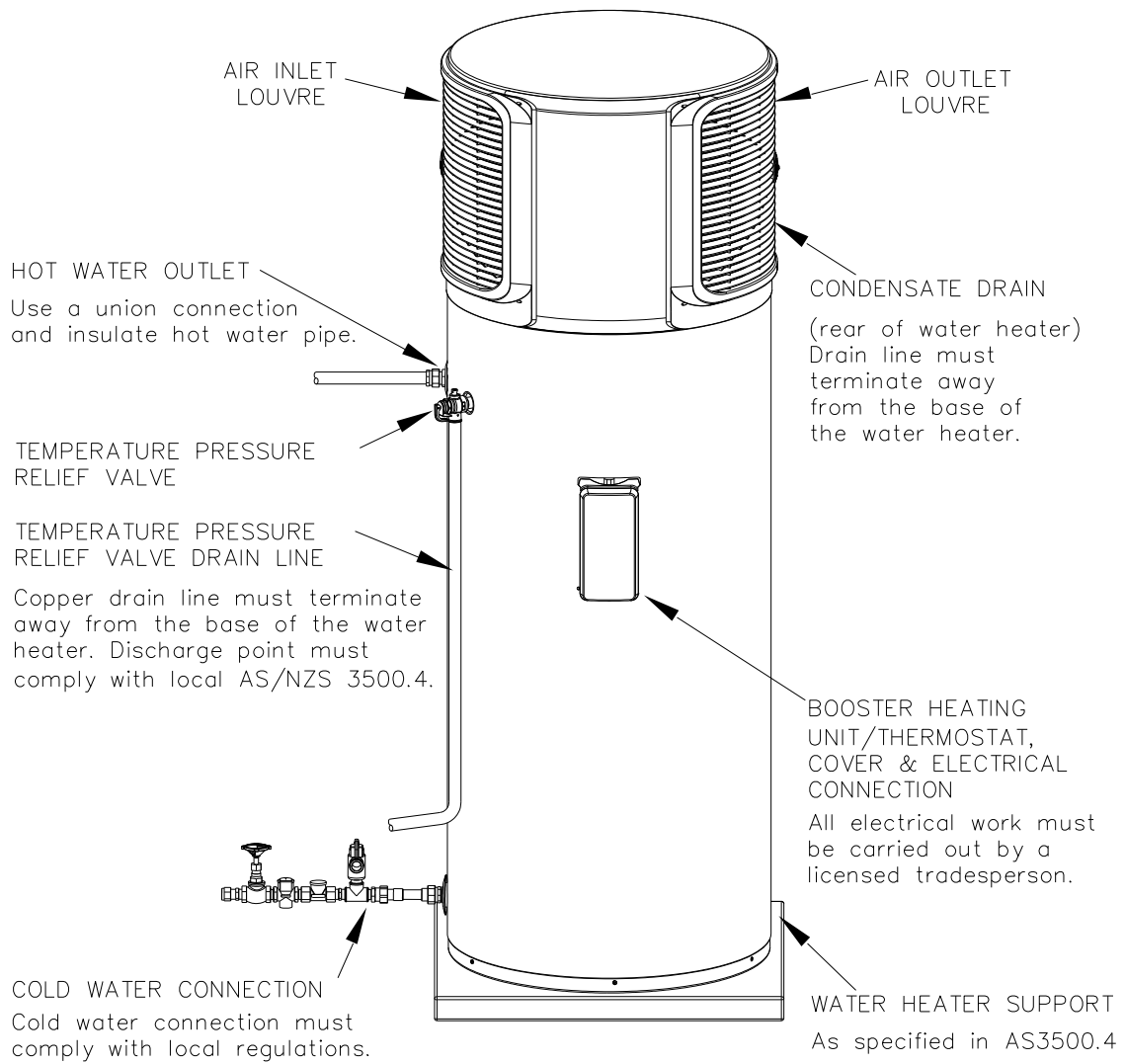

**DIMENSIONS AND TECHNICAL DATA**

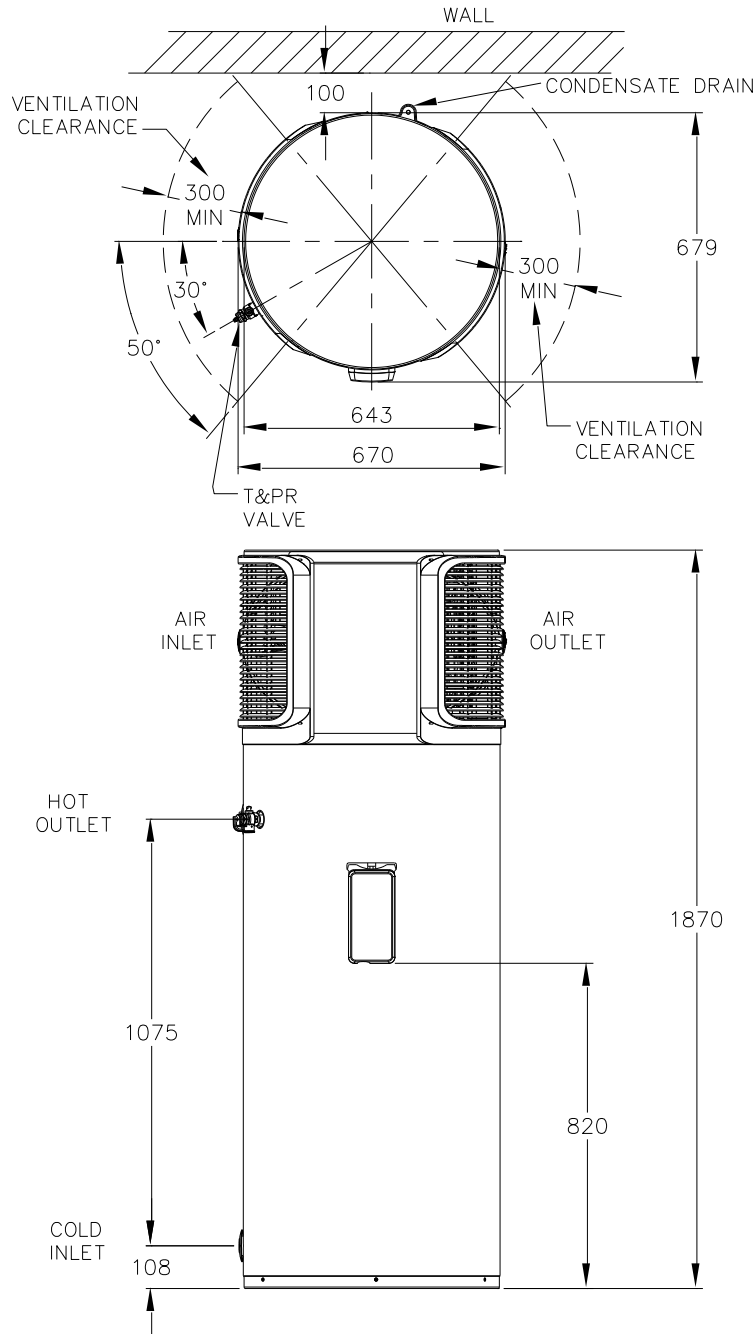

<b>System number</b>		551 310
<b>Model Number</b>	1.8 kW	551 310 04
	2.4 kW	551 310 05
	3.6 kW	551 310 07

<b>Part numbers</b>	
Tank only 1.8 kW	T551 310 04
Tank only 2.4 kW	T551 310 05
Tank only 3.6 kW	T551 310 07
Heat pump module	180532

<b>Maximum rated power input</b>	3600 watts
<b>Rated heat pump power input</b>	1300 watts
<b>Booster element rating</b>	1800, 2400 or 3600 watts
<b>Refrigerant type</b>	R134a
<b>Refrigerant circuit pressure</b>	3000 kPa

<b>Storage capacity</b>	310 litres
<b>Boost capacity</b>	220 litres
<b>Mass empty - total</b>	135 kg
Storage tank	87 kg
Heat pump module	48 kg
<b>Mass full - total</b>	445 kg

Technical data is subject to change.

---

## HEAT PUMP AND TANK ASSEMBLY

---

### STORAGE TANK AND HEAT PUMP MODULE

The heat pump water heater is made of two main components, the storage tank and the heat pump module. For transport and handling (weight) purposes both items are shipped separately and designed to be assembled at the installation site. The water heater must not be operated until both components are assembled.

### HEAT PUMP MODULE

The heat pump module is to be mounted on the top of the storage tank. It is designed so that it can be lifted to the top of the storage tank by two people. It is shipped in a box containing two lifting bars that are inserted into the heat pump module to facilitate lifting.

**CAUTION:** The heat pump module weighs approximately 48 kg. Use the lifting bars provided to lift and mount to the top of the storage tank. Good lifting practice should be followed.

There are two flexible hoses provided inside the heat pump module. The flexible hoses are to be fixed to the two water fittings on the top of the storage tank during the assembly procedure.

There are two connection points located on the control board behind the electrical cover in the heat pump module to which the power cable and tank sensor cable from the storage tank are connected during the assembly procedure.

### STORAGE TANK

The storage tank must be fully supported by a level slab or solid base. The storage tank is designed to support the heat pump module.

There are two water fittings located at the top of the storage tank to which flexible hoses from the heat pump module are connected during the assembly procedure.

A power cable and a tank sensor cable protrude from the top of the storage tank. These are to be connected to the control board behind the electrical cover in the heat pump module during the assembly procedure.

heat pump module

storage tank

heat pump water heater

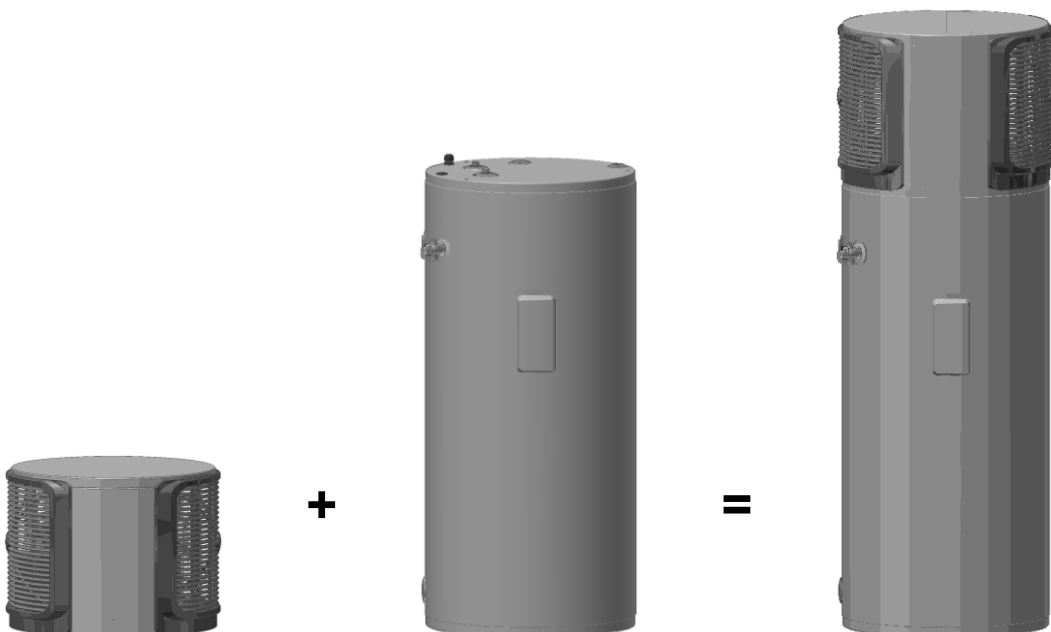

**ASSEMBLY PROCEDURE**

**⚠ Warning:** The heat pump must be assembled, plumbed and filled with water prior to power being connected and switched on.

The following procedure should be followed to properly lift, place and connect the heat pump module onto the storage tank:

1. **Storage Tank:** Remove all packaging including the carton base from the storage tank and position in its intended location, supported by a level slab or solid base.

The water connections are on the left hand side and should be parallel to the wall, unless the water heater is to be installed in a manifolded bank of water heaters. If the water heater is installed in a manifolded bank of water heaters, refer to “Multiple Installations” on page 33 for information on the correct storage tank orientation.

The storage tank is to be positioned at least 100 mm from the wall and such that when the heat pump module is in position on top of the storage tank, there is a clearance of at least 300 mm perpendicular from both the air inlet and outlet louvres to any wall or obstruction.

- Ensure the power cable and tank sensor cable are hanging down the side of and not sitting on top of the storage tank before lifting the heat pump module into position.

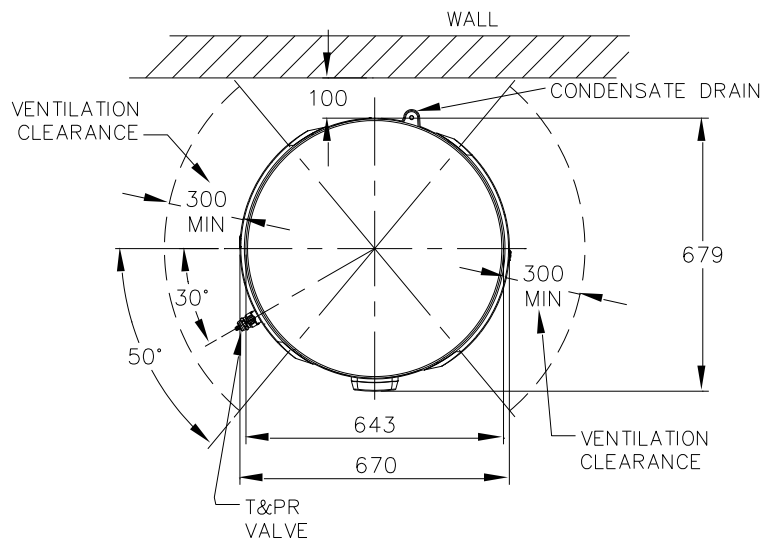

**Step 1**  
**position storage tank at least 100 mm from the wall**  
**and allow for at least 300 mm ventilation clearance**

2. **Heat Pump Module:** Place the heat pump module in front of the storage tank and open the top flaps of the carton.

Two (2) lifting bars are housed in a recess in the cardboard layer on top of the heat pump module.

- Remove the lifting bars and set them aside.
- Remove the carton from the heat pump module.

Be aware the carton sides have flaps, which tuck under the carton base of the heat pump module.

3. **Air Louvre Removal:** Using a Phillips head screw driver, remove the six (6) screws from each of the two air louvres (twelve (12) screws in total).
  - Remove the louvres from the heat pump module.
4. **Electrical Cover:** Remove the mounting screw from the side of the electrical cover.
  - Gently remove the cover.

The electrical cover needs to be handled gently so as not to damage the electronic controls located behind the electrical cover.

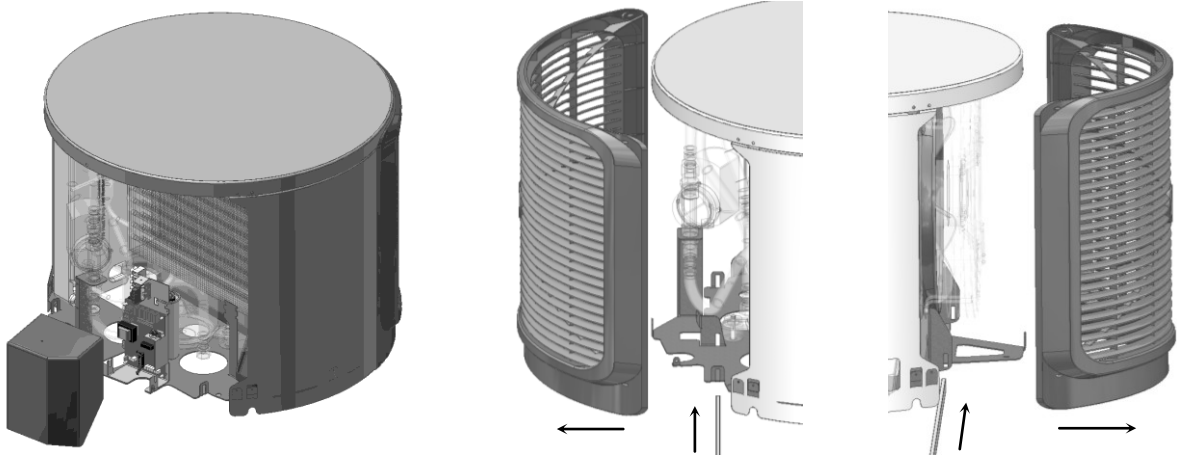

**Step 4**  
remove electrical cover

**Steps 3 and 5**  
remove louvres and insert lifting bars into the slots provided

5. **Lifting Bars:** Insert the two (2) lifting bars into the slots at the front of the heat pump module chassis and carefully push through to engage the slots at the rear.

Take care not to catch any of the wiring or hoses in the heat pump module.

Leave sufficient overhang at either end to enable a firm and safe grip for lifting the heat pump module onto the top of the storage tank.



6. **Heat Pump Module Placement:** Using **two** people, one person on each lifting bar, lift the heat pump module and place it on the top of the storage tank.

It is recommended to place the hands under the bar to enable the lift in a curl action.

- Ensure the two water fittings on the storage tank pass through the openings marked “INLET” and “OUTLET” on the heat pump module chassis.
- Ensure the three screw holes in the bottom plate of the chassis are lined up with the three nutserts in the top of the storage tank.

Take care to avoid resting the heat pump module on the power cable or the tank sensor cable.

Final positioning is best undertaken with the lifting bars still in position.

**CAUTION: The heat pump module weighs approximately 48 kg. This operation should be performed carefully by two people and good lifting practice should be followed.**

7. **Heat Pump Module Attachment:** Remove the two (2) lifting bars and attach the heat pump module to the storage tank with the three (3) M6 screws provided with the heat pump module.

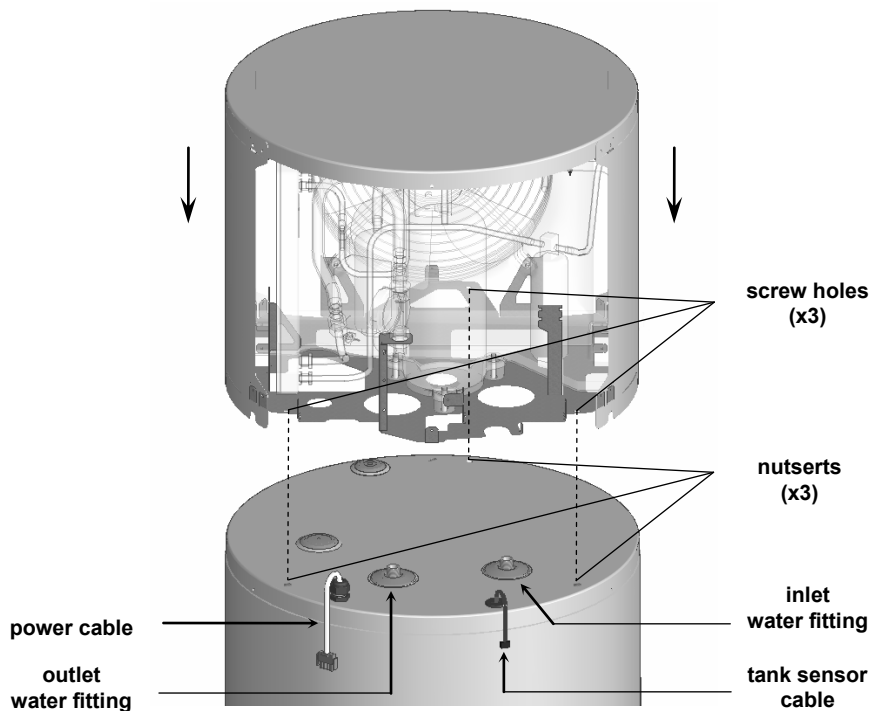

**Steps 6 and 7  
install heat pump module to storage tank**

8. **Water Fitting Caps:** Remove the caps from the inlet and outlet water fittings on the top of the storage tank. These may be unscrewed or cut from the fittings if necessary.

Take care not to loosen the fittings or damage the threads whilst removing the caps.

9. **Inlet Flexible Braided Hose:** Attach the flexible braided hose marked “INLET” to the water fitting marked “INLET”.
- Tighten the swivel nut on the hose using a 24 mm spanner.
  - Push down the pipe seal ring to seat over the swivel nut and against the pipe seal cover.

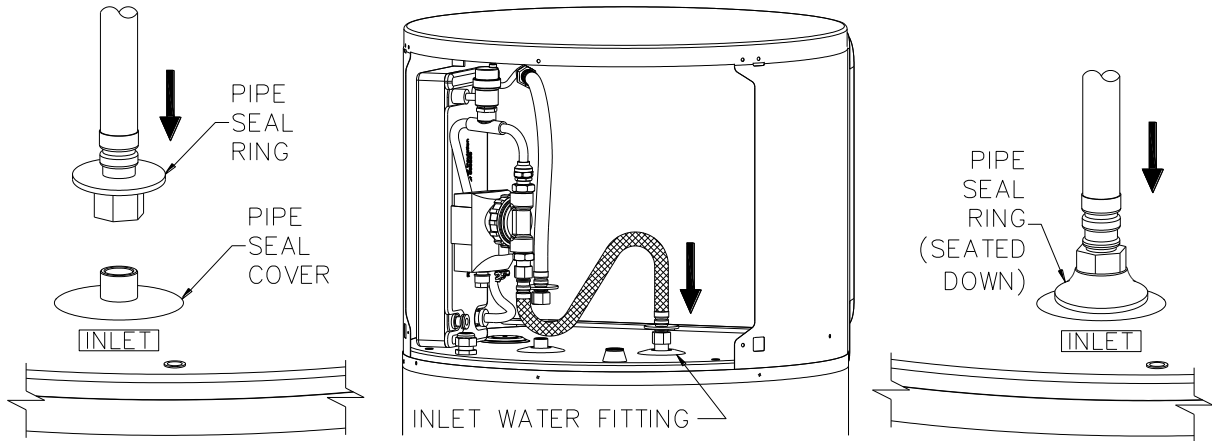

**Step 9**  
**attach inlet water hose and seat pipe seal ring**

10. **Outlet Flexible Braided Hose:** Attach the flexible braided hose marked “OUTLET” to the water fitting marked “OUTLET”.
- Tighten the swivel nut on the hose using a 24 mm spanner.
  - Push down the pipe seal ring to seat over the swivel nut and against the pipe seal cover.

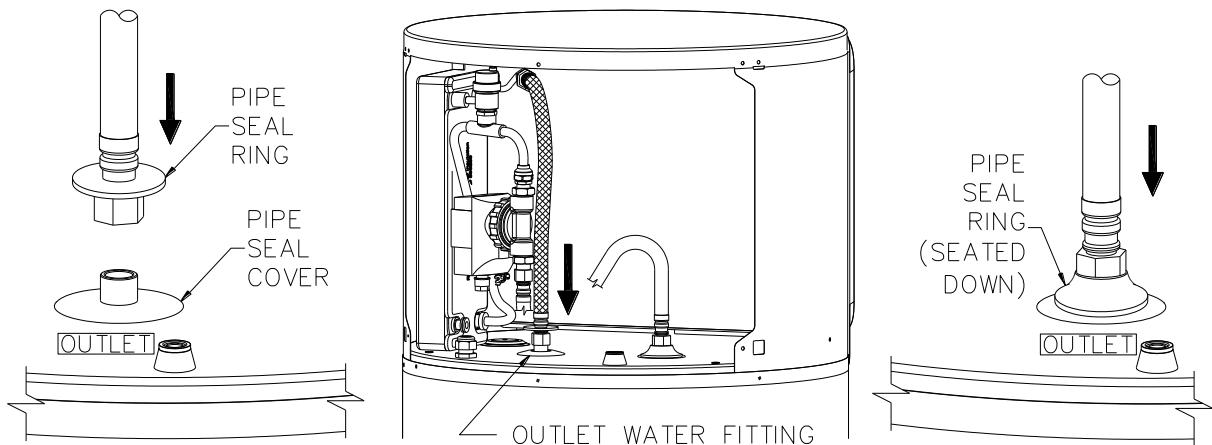

**Step 10**  
**attach outlet water hose and seat pipe seal ring**

11. **Air Bleed Valve:** Open the air bleed valve screw by rotating anticlockwise one turn.

This will allow air to bleed from the circulator and flexible hose during the filling of the tank process.

- Leave the screw in this position.
- Ensure the screw is not removed, nor left screwed shut.

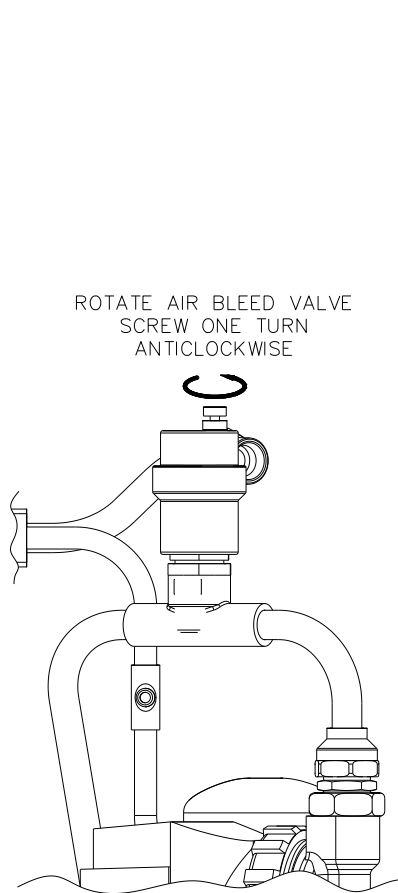

**Step 11**  
open air bleed valve screw  
by rotating one turn anticlockwise

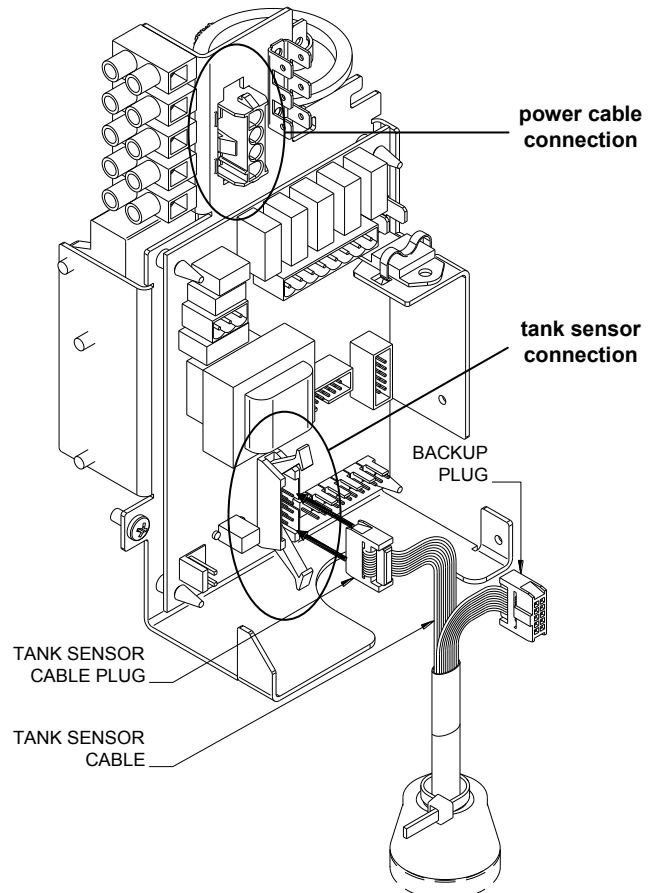

**Steps 12 and 13**  
connect power cable and tank sensor cable

12. **Tank Sensor Cable Connection:** Insert ONE tank sensor cable plug firmly into the connector marked "TANK SENSOR" at the bottom of the control board.

**Note:** There are two tank sensor cables protruding through the top of the storage tank, each with a tank sensor cable plug. Only **ONE** tank sensor cable plug is to be connected to the control board. The second plug is a backup plug and is not to be connected to any part of the control board.

- Ensure the plug is fully inserted so the holding clips on the board automatically engage the plug.
- Coil up both the excess length of tank sensor cable and the spare cable and plug for storage behind the electrical cover when refitted.

Do not allow the cables and spare plug to hang loose outside of the control board enclosure as damage to these components could occur.

13. **Power Cable Connection:** Connect the four (4) pin power cable plug to the connector at the top of the control board.

- Ensure the plug fully engages the locking feature on the connector.

14. **Electrical Cover:** Replace the electrical cover, engaging the bottom of the cover into the slots on the supporting bracket.
  - Secure at the side with the mounting screw.
15. **Water Connections:** Connect the cold water supply and the hot water pipe work to the water heater.
  - Connect the temperature pressure relief valve and its drain line.  
Refer to “[Connections – Plumbing](#)” on page 29
16. **Water Supply:** Turn on the cold water supply and fill the water heater.
  - Check the pipe work and the inlet and outlet connection points of the flexible hoses for leaks.  
Refer to “[To Fill And Turn On The Water Heater](#)” on page 36, however the electrical supply should not be switched on at this stage.
17. **Air Louvre Attachment:** Replace the two air louvres, ensuring the longer skirt of the louvre is orientated to the bottom and re-fit all twelve (12) louvre attachment screws.
18. **Electrical Connection:** Refer to “[Connections – Electrical](#)” on page 31.
19. **Commissioning:** Refer to “[Commissioning](#)” on page 36.

---

## CONNECTIONS – PLUMBING

---

All plumbing work must be carried out by a qualified person and in accordance with the Standard AS/NZS 3500.4 and all local codes and regulatory authority requirements. In New Zealand, the installation must conform with Clause G12 of the New Zealand Building Code.

### CONNECTION SIZES

- Hot water connection: RP $\frac{3}{4}$ /20.
- Cold water connection: RP $\frac{3}{4}$ /20.
- Relief valve connection: RP $\frac{1}{2}$ /15.

### WATER INLET AND OUTLET

The pipe work must be cleared of foreign matter before connection and purged before attempting to operate the water heater. All olive compression fittings must use brass or copper olives. Use thread sealing tape or approved thread sealant on all fittings.

An isolation valve and non return valve must be installed on the cold water line to the water heater. An acceptable arrangement is shown in the diagram. Refer also to “Hot Water Delivery” on page 17 and to “Mains Water Supply” on page 16.

A disconnection union must always be provided at the cold water inlet and hot water outlet on the water heater to allow for disconnection of the water heater.

This water heater has either a plastic dip tube or fitting liner in the inlet and outlet fittings (see diagram). These must be in place for the water heater to function properly. Do not remove or damage them by using heat nearby. They will be pushed into the correct position as the fitting is screwed in.

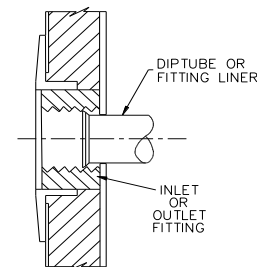
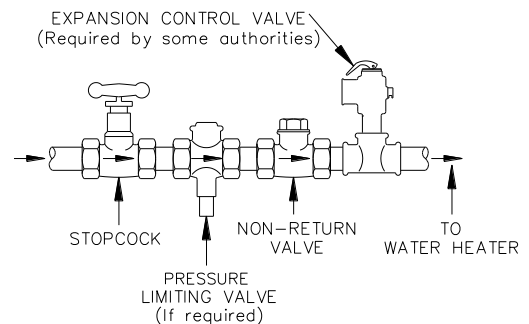

### PIPE SIZES

To achieve true mains pressure operation, the cold water line to the water heater should be the same size or bigger than the hot water line from the water heater.

The pipe sizing for hot water supply systems should be carried out by persons competent to do so, choosing the most suitable pipe size for each individual application. Reference to the technical specifications of the water heater and local regulatory authority requirements must be made.

### TEMPERATURE PRESSURE RELIEF VALVE

The temperature pressure relief valve is shipped behind the front cover or of the water heater. The temperature pressure relief valve must be fitted before the water heater is operated. Before fitting the relief valve, make sure the probe has not been bent. Seal the thread with Teflon tape - never hemp. Make sure the tape does not hang over the end of the thread.

Screw the valve into the correct opening (refer to the [installation diagram on page 20](#)) leaving the valve drain pointing downwards. Do not use a wrench on the valve body - use the spanner flats provided. A copper drain line must be fitted to the temperature pressure relief valve (refer to "[Relief Valve Drain](#)" on page 30).

The valve must be insulated with closed cell polymer insulation or similar (minimum thickness 9 mm) and the insulation installed so as not to impede the operation of the valve. The insulation must be weatherproof and UV resistant if exposed.

**EXPANSION CONTROL VALVE**

Local regulations may make it mandatory to install an expansion control valve (ECV) in the cold water line to the water heater. In other areas, an ECV is required if the saturation index is greater than +0.4 (refer to "Water Supplies" on page 10).

The expansion control valve must always be installed after the non return valve and be the last valve installed prior to the water heater (refer to diagram on page 29). A copper drain line must be fitted to the expansion control valve (refer to "Relief Valve Drain" on page 30).

The valve must be insulated with closed cell polymer insulation or similar (minimum thickness 9 mm) and the insulation installed so as not to impede the operation of the valve. The insulation must be weatherproof and UV resistant if exposed.

**RELIEF VALVE DRAIN**

DN15 copper drain lines must be fitted to the temperature pressure relief valve and expansion control valve (if one is installed) to carry the discharge clear of the water heater. Connect the drain lines to the valves using disconnection unions. The drain line from the valve to the point of discharge should be as short as possible, have a continuous fall all the way from the water heater to the discharge outlet and have no tap, valves or other restrictions in the pipe work.

A drain line from a relief valve must comply with the requirements of AS/NZS 3500.4.

A drain line must be no longer than 9 metres with no more than three bends greater than 45° before discharging at an outlet or air break. The maximum length of 9 metres for a drain line is reduced by 1 metre for each additional bend required of greater than 45°, up to a maximum of three additional bends. Where the distance to the point of final discharge exceeds this length, the drain line can discharge into a tundish.

Subject to local regulatory authority approval, the drain lines from the temperature pressure relief valve and expansion control valve from an individual water heater may be interconnected.

The outlet of a drain line must be in such a position that flow out of the pipe can be easily seen, but arranged so discharge will not cause injury, damage or nuisance. The termination point of a drain line must comply with the requirements of AS/NZS 3500.4. Drain lines must not discharge into a safe tray.

In locations where water pipes are prone to freezing, drain lines must be insulated, must not exceed 300 mm in length and are to discharge into a tundish through an air gap of between 75 mm and 150 mm.

If a drain line discharges into a tundish, the drain line from the tundish must be not less than DN20. The drain line from a tundish must meet the same requirements as for a drain line from a relief valve.

For multiple installations the drain lines from several water heaters can discharge into a common tundish (refer to "Multiple Installations" on pages 33 to 35).

**Warning:** As the function of the temperature pressure relief valve on this water heater is to discharge high temperature water under certain conditions, it is strongly recommended the pipe work downstream of the relief valve be capable of carrying water exceeding 93°C. Failure to observe this precaution may result in damage to pipe work and property.

**CONDENSATE DRAIN**

A drain line must be fitted to the condensate drain to carry the discharge clear of the water heater. The drain line can be extended using 13 mm rigid hose or conduit. The pipe work from the condensate drain should be as short as possible, and fall all the way from the water heater with no restrictions. It should have no more than three right angle bends in it. The outlet of the drain line must be in such a position that flow out of the pipe can be easily seen - but arranged so water discharge will not cause damage or nuisance.

**The condensate drain line must not be connected to the relief valves drain lines but may discharge at the same point.**

---

## CONNECTIONS – ELECTRICAL

---

**The power supply to the water heater must not be switched on until the water heater is filled with water and a satisfactory megger reading is obtained.**

### MEGGER READING

When a megger test is conducted on this water heater, then the following should be noted.

**⚠ Warning:** This water heater contains electronic equipment and 500 V insulation tests must only be conducted between active and earth and between neutral and earth. An active to neutral test WILL damage the electronics.

**An insulation test result of between 100 KΩ and 660 KΩ for this water heater is normal.**

Typically the insulation resistance between live and earthed parts of an electrical installation should not be less than 1 MΩ. However AS/NZS 3000:2000 clause 6.3.3.3.2 'Results' states:

“The value of 1 MΩ may be reduced to:

- 0.01 MΩ for sheathed heating elements or appliances; or
- a value permitted in the Standard applicable to electrical equipment.”

This model water heater is categorised as a 'stationary class 1 motor operated appliance' and has been tested to AS/NZS 3350.1:2002 clause 16 'Leakage current and electric strength' and has passed the requirements of this Standard. Therefore, this model water heater complies with the condition stated in AS/NZS 3000:2000 clause 6.3.3.3.2 (b).

### ELECTRICAL CONNECTION

All electrical work and permanent wiring must be carried out by a qualified person and in accordance with the Wiring Rules AS/NZS 3000 and all local codes and regulatory authority requirements.

The water heater must be directly connected to a 240 V AC 50 Hz mains power supply. The water heater must be on its own circuit with an isolating switch installed at the switchboard. A secondary isolating switch may be installed within reach of the water heater.

The 551 310 model heat pump water heater is recommended for connection to a minimum 16 hour per day power supply.

A flexible 20 mm conduit is required for the electrical cable to the water heater. The conduit is to be connected to the unit with a 20 mm terminator. Connect the power supply wires directly to the terminal block and earth tab connection, ensuring there are no excess wire loops inside the front cover.

The water heater will only operate on a sine wave at 50 Hz. Devices generating a square wave cannot be used to supply power to the water heater.

### BOOSTER HEATING UNIT AND THERMOSTAT SETTING

The water heater has a booster heating unit and thermostat. The booster heating unit will be automatically activated during periods when the ambient air temperature falls below 5°C and heating of the water is required. The thermostat is not adjustable.

### TIMER

A timer can be installed in the electrical circuit to the water heater. The timer must be weatherproof if it is installed outdoors.

It may be desirable for the water heater not to operate between certain hours, such as during the peak period when connected to a Time of Use electricity supply due to a more expensive tariff rate applying. A timer will affect the operating times of both the heat pump circuit and the booster heating unit.

**Note:** The 551 310 model heat pump water heater is recommended for connection to a minimum 16 hour per day power supply.

WIRING DIAGRAM

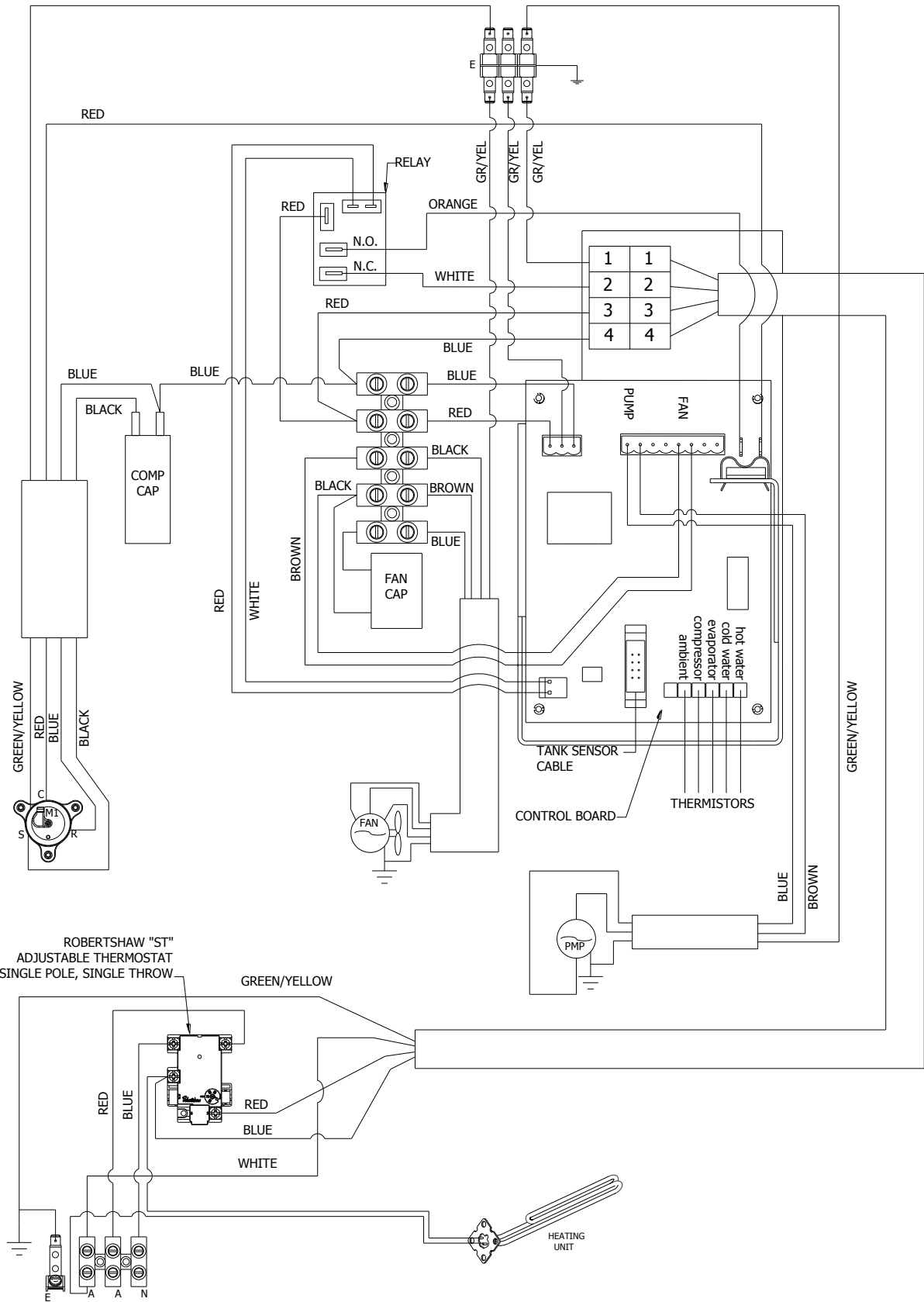

Electrical Circuit for Heat Pump – Robertshaw “ST” Thermostat



---

## MULTIPLE INSTALLATIONS

---

A multiple installation of Rheem heat pump water heaters on a single manifold or multiple manifolds is possible, using the Equa-Flow<sup>®</sup> manifold system, where large volumes of hot water is required. The Equa-Flow principle will function with water heaters in line, around a corner or in rows back to back (refer to the diagrams on pages 34 to 35).

The cold water and hot water manifolds must be designed to balance the flow from each water heater. To achieve this, there are basic installation requirements and principles which must be followed:

1. The maximum number of water heaters in a bank should be 8, however several banks of water heaters can be installed.
2. The hot water line from the manifold must leave from the opposite end to which the cold water line enters the manifold.
3. The water heaters must be of the same model.
4. The cold water line, cold and hot headers and hot water line must be sized to meet the requirements of both AS/NZS 3500.4 and the application.
5. A non return valve, isolation valve and if required a pressure limiting valve and expansion control valve, must be installed on the cold water line to the system.
6. A full flow gate valve or ball valve (not a stop tap, as used on a single water heater installation) must be installed on both the cold water branch and hot water branch of each water heater.
7. Non return valves or pressure limiting valves must not be installed on the branch lines to the water heaters.
8. All fittings, valves and branch lines must be matched sets all the way along the manifold.
9. Sufficient space must be left to enable access, servicing or removal of any water heater.
10. The temperature pressure relief valve drain line from each water heater can terminate at a common tundish (funnel) with a visible air break at each drain discharge point (refer to the diagram on page 34 and to "Relief Drain Line" on page 30).

Refer to the diagrams on pages 34 to 35 for installation and plant layout details.

In addition to the basic installation requirements and principles of manifolding, the following requirements for manifolding heat pump water heaters of this model must be followed:

1. The heat pump water heaters must be turned through 90° from a standard installation, with the front cover facing the back of the adjacent water heater. This is to ensure the air intake and air discharge of the heat pump are parallel to the adjacent heat pump water heater.
2. If the installation is alongside or adjacent to a wall, it is recommended to install the water heater with the air intake facing in the direction of the wall and the air discharge facing away from the wall.
3. A minimum of 900 mm is required between the heat pump water heater and a wall to enable access and servicing of the heat pump system.
4. A minimum of 900 mm is required between and in front of each heat pump water heater to enable access, servicing or removal of the water heater.
5. A circulated hot water flow and return system must not be returned back into the heat pump water heaters (refer to "Circulated Flow and Return System" on page 18).

**TYPICAL INSTALLATION – MULTIPLE HEAT PUMP WATER HEATERS**

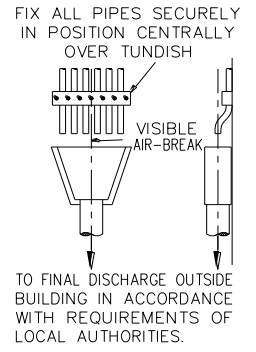
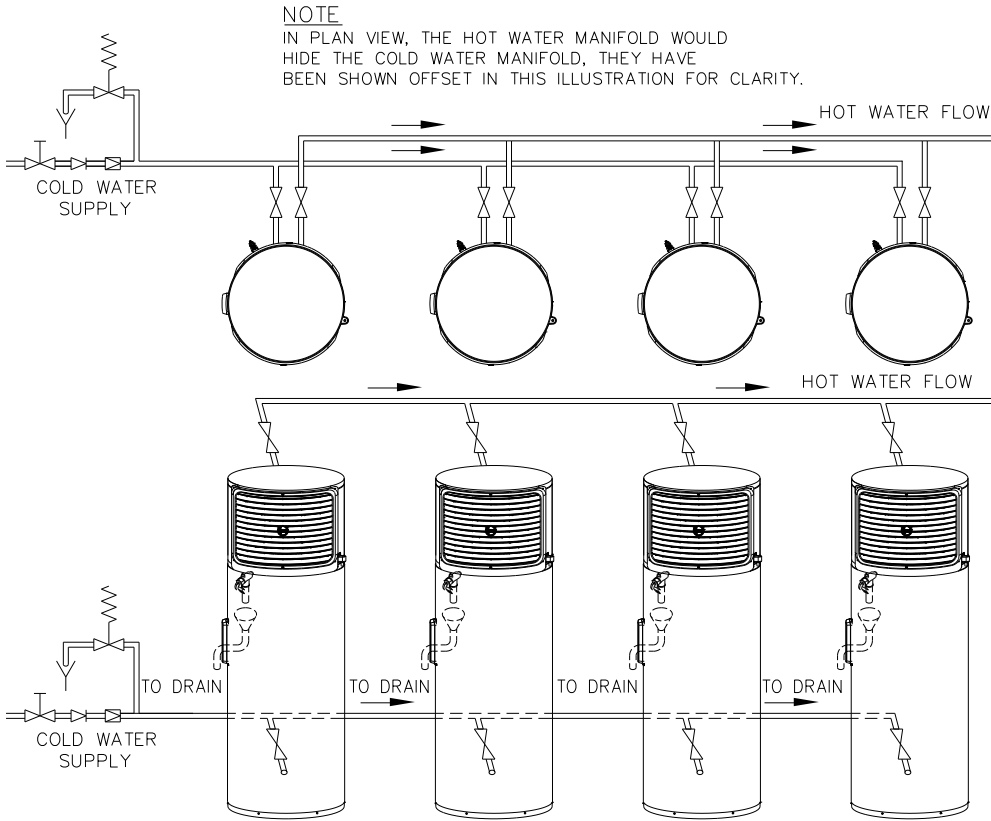

**TPR Valve Drain Line Common Discharge Point**

**INSTALLATION DIMENSIONS – MULTIPLE HEAT PUMP WATER HEATERS**

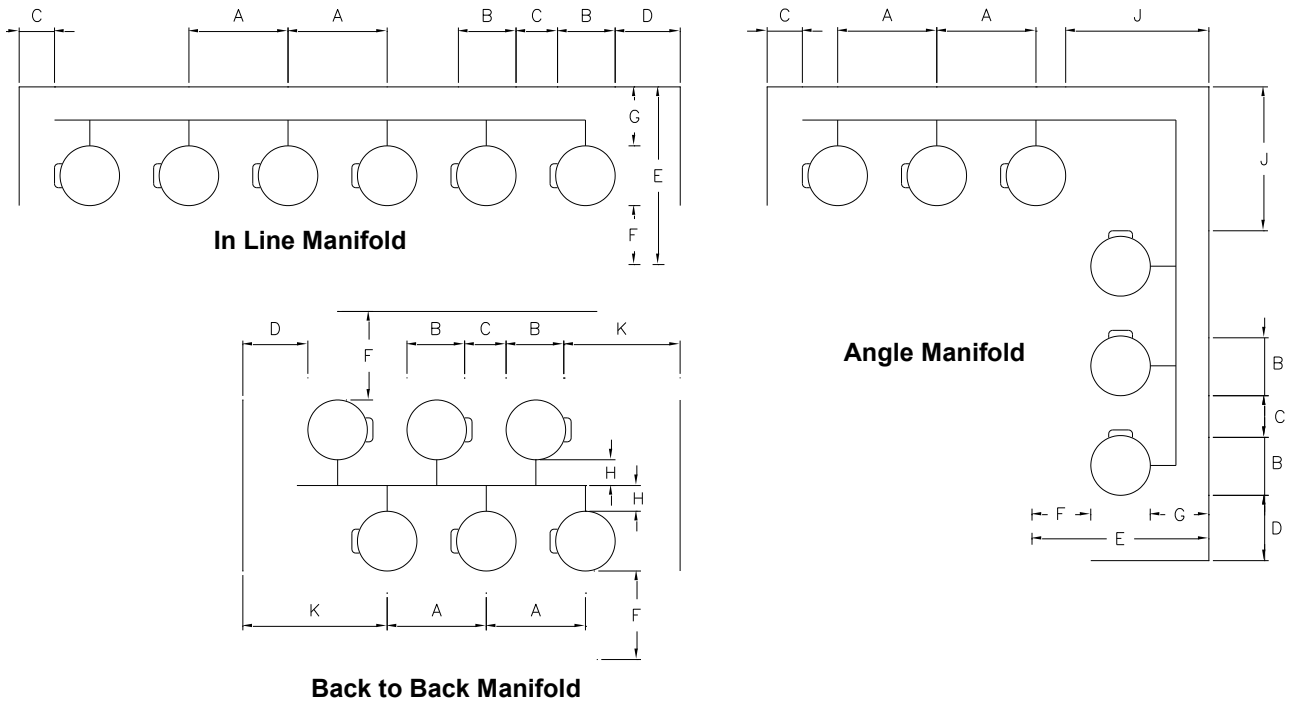

**Notes**

1. A minimum clearance of 900 mm (C\*, F\* & G\*) should be left in front and at the sides of the water heater for access, servicing and water heater removal.
2. Air flow through the heat pump must be parallel to the adjacent heat pump water heater.

Installation Layout Minimum Dimensions										
Model	A	B	C*	D	E	F*	G*	H	J	K
310 HAV	1545	645	900	900	2445	900	900	300	1670	1675

**MANIFOLD ARRANGEMENT**

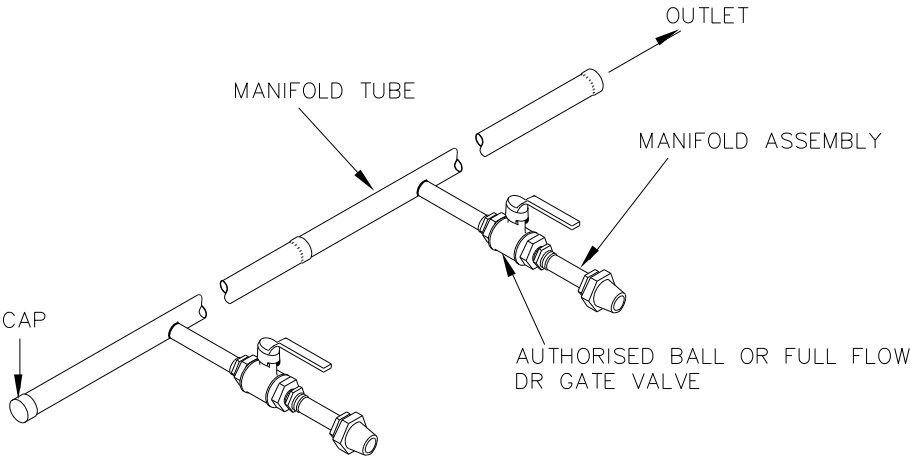

**Hot Manifold Assembly**

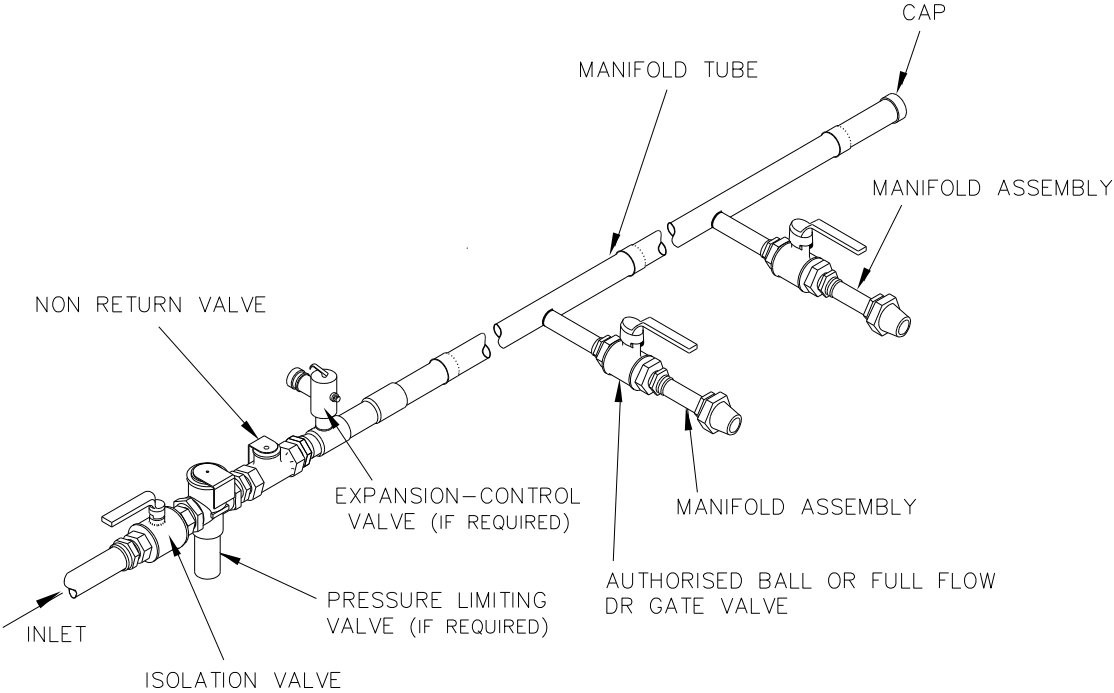

**Cold Manifold Assembly**

---

## COMMISSIONING

---

### TO FILL AND TURN ON THE WATER HEATER

The power supply to the water heater must not be switched on until the water heater is filled with water and a satisfactory megger reading is obtained.

- Open all of the hot water taps in the house (don't forget the shower).
- Open the cold water isolation valve fully to the water heater.  
Air will be forced out of the taps.
- Close each tap as water flows freely from it.
- Check the pipe work for leaks.
- Switch on the electrical supply at the isolating switch to the water heater.
- Set the timer if one is installed.

The heat pump may take up to 30 seconds to commence operating when the power supply is switched on. The heat pump will only operate when the water in the storage tank requires heating, the heat pump compressor is cool and power is available at the water heater. If the ambient air temperature is below the minimum operating temperature of 5°C and the system calls for heating, the booster heating unit will operate instead.

When the heat pump is operating, the system may switch to the booster heating unit if it detects that the ambient air temperature is below the minimum operating temperature of 5°C. It may also switch back to heat pump operation from the booster heating unit if it detects the ambient air temperature has moved back to within the heat pump's operating temperature range.

**Note:** The heat pump may not turn on after having just completed a heating cycle and more hot water is drawn from the water heater. The heat pump will wait until the compressor has cooled down and the conditions for start up are favourable, in order to protect the compressor from damage. This may take up to 20 minutes from the last heating cycle.

It is important to wait for five minutes after the heat pump has activated to ensure it continues to operate and is functioning correctly.

Explain to the householder or a responsible officer the functions and operation of the heat pump water heater. Upon completion of the installation and commissioning of the water heating system, leave this guide with the householder or a responsible officer.

### TO TURN OFF THE WATER HEATER

If it is necessary to turn off the water heater on completion of the installation, such as on a building site or where the premises are vacant, then:

- Switch off the electrical supply at the isolating switch to the water heater.
- Close the cold water isolation valve at the inlet to the water heater.

---

## DRAINING THE WATER HEATER

---

 **Warning:** Exercise care, as water discharged from the water heater may be of a very high temperature.

To drain the water heater:

- Turn off the water heater (refer to “[To Turn Off The Water Heater](#)” on page 36).
- Close all hot water taps.
- Operate the relief valve release lever - do not let the lever snap back or you will damage the valve seat.

Operating the lever will release the pressure in the water heater.

- Undo the union at the cold water inlet and attach a hose.

Let the other end of the hose go to a drain.

- Operate the relief valve again.

This will let air into the water heater and allow the water to drain through the hose.

---

This page is intentionally blank.

---

# RHEEM HEAT PUMP WATER HEATER WARRANTY - AUSTRALIA ONLY -

---

## HEAT PUMP WATER HEATER MODEL 551310

### 1. THE RHEEM WARRANTY – GENERAL

- 1.1 This warranty is given by Rheem Australia Pty Limited ABN 21 098 823 511 of 1 Alan Street, Rydalmere New South Wales.
- 1.2 Rheem offer a trained and qualified national service network who will repair or replace components at the address of the water heater subject to the terms of the Rheem warranty. Rheem Service, in addition can provide preventative maintenance and advice on the operation of your water heater. The Rheem Service contact number is available 7 days a week on 131 031 with Service personnel available to take your call from 8am to 8pm daily (hours subject to change).
- 1.3 For details about this warranty, you can contact us on 131 031 or by email at [warrantyenquiry@rheem.com.au](mailto:warrantyenquiry@rheem.com.au) (not for service bookings).
- 1.4 The terms of this warranty are set out in section 2 and apply to water heaters manufactured after 1<sup>st</sup> January 2012.
- 1.5 If a subsequent version of this warranty is published, the terms of that warranty will apply to water heaters manufactured after the date specified in the subsequent version.

### 2. TERMS OF THE RHEEM WARRANTY AND EXCLUSIONS TO IT

- 2.1 The decision of whether to repair or replace a faulty component is at Rheem's sole discretion.
- 2.2 Where a failed component or cylinder is replaced under this warranty, the balance of the original warranty period will remain effective. The replacement does not carry a new Rheem warranty.
- 2.3 Where the water heater is installed outside the boundaries of a metropolitan area as defined by Rheem or further than 25 km from either a regional Rheem branch office or an Accredited Rheem Service Agent's office, the cost of transport, insurance and travelling between the nearest branch office or Rheem Accredited Service Agent's office and the installed site shall be the owner's responsibility.
- 2.4 Where the water heater is installed in a position that does not allow safe or ready access, the cost of that access, including the cost of additional materials handling and/or safety equipment, shall be the owner's responsibility. In other words, the cost of dismantling or removing cupboards, doors or walls and the cost of any special equipment to bring the water heater to floor or ground level or to a serviceable position is not covered by this warranty.
- 2.5 This warranty only applies to the original and genuine Rheem water heater in its original installed location and any genuine Rheem replacement parts.
- 2.6 If the water heater is not sized to supply the hot water demand in accordance with the guidelines in the Rheem water heater literature, any resultant fault will not be covered by the Rheem warranty.
- 2.7 The Rheem warranty does not cover faults that are a result of:
  - a) Accidental damage to the water heater or any component (for example: (i) Acts of God such as floods, storms, fires, lightning strikes and the like; and (ii) third party acts or omissions).
  - b) Misuse or abnormal use of the water heater.
  - c) Installation not in accordance with the Owner's Guide and Installation Instructions or with relevant statutory and local requirements in the State or Territory in which the water heater is installed.
  - d) Connection at any time to a water supply that does not comply with the water supply guidelines as outlined in the Owner's Guide and Installation Instructions.
  - e) Repairs, attempts to repair or modifications to the water heater by a person other than Rheem Service or a Rheem Accredited Service Agent.
  - f) Faulty plumbing or faulty power supply.
  - g) Failure to maintain the water heater in accordance with the Owner's Guide and Installation Instructions.
  - h) Transport damage.
  - i) Fair wear and tear from adverse conditions (for example, corrosion).
  - j) Cosmetic defects.
- 2.8 If you require a call out and we find that the fault is not covered by the Rheem warranty, you are responsible for our standard call out charge. If you wish to have the relevant component repaired or replaced by Rheem, that service will be at your cost.
- 2.9 Subject to any statutory provisions to the contrary, this warranty excludes any and all claims for damage to furniture, carpet, walls, foundations or any other consequential loss either directly or indirectly due to leakage from the water heater, or due to leakage from fittings and/ or pipe work of metal, plastic or other materials caused by water temperature, workmanship or other modes of failure.

# RHEEM HEAT PUMP WATER HEATER WARRANTY - AUSTRALIA ONLY -

## HEAT PUMP WATER HEATER MODELS 551310

### 3. WHAT IS COVERED BY THE RHEEM WARRANTY FOR THE WATER HEATERS DETAILED IN THIS DOCUMENT

3.1 Rheem will repair or replace a faulty component of your water heater if it fails to operate in accordance with its specifications as follows:

What components are covered	The period in which the fault must appear in order to be covered	What coverage you receive
All components	Year 1	Repair and/or replacement of the faulty component, free of charge, including labour.
<b>Sealed System*</b> components (only if the water heater is installed in a single-family domestic dwelling)	Year 2	Repair and/or replacement of the faulty component, free of charge, including labour.
<b>The cylinder</b> (if the water heater is installed in a single-family domestic dwelling)	Years 2 & 3	Repair and / or replacement of the cylinder, free of charge, including labour.
	Years 4 & 5	Replacement cylinder, free of charge. Installation and repair labour costs are the responsibility of the owner.
<b>The cylinder</b> (if the water heater is <u>not</u> installed in a single-family domestic dwelling)	Years 2 & 3	Replacement cylinder, free of charge. Installation and repair labour costs are the responsibility of the owner.

\* The Sealed System includes components that carry refrigerant only, e.g. Compressor, Condenser, TX Valve, Receiver / Drier, Evaporator and associated pipe work.

3.2 If a government rebate has been received for the water heater, the duration of the protection afforded by this warranty may be greater than what is set out above. Please call 131 031 for details.

### 4. ENTITLEMENT TO MAKE A CLAIM UNDER THIS WARRANTY

4.1 To be entitled to make a claim under this warranty you need to:

- a) Be the owner of the water heater or have consent of the owner to act on their behalf
- b) Contact Rheem Service without undue delay after detection of the defect and, in any event, within the applicable warranty period.

4.2 You are not entitled to make a claim under this warranty if your water heater:

- a) Does not have its original serial numbers or rating labels.
- b) Is not installed in Australia.

### 5. HOW TO MAKE A CLAIM UNDER THIS WARRANTY

5.1 If you wish to make a claim under this warranty, you need to:

- a) Contact Rheem on 131031 and provide owner's details, address of the water heater, a contact number and date of installation of the water heater or if that's unavailable, the date of manufacture and serial number (from the rating label on the water heater)
- b) Rheem will arrange for the water heater to be tested and assessed on-site.
- c) If Rheem determines that you have a valid warranty claim, Rheem will repair or replace the water heater in accordance with this warranty

5.2 Any expenses incurred in the making of a claim under this warranty will be borne by you.

### 6. THE AUSTRALIAN CONSUMER LAW

6.1 Our goods come with guarantees that cannot be excluded under the Australian Consumer Law. You are entitled to a replacement or refund for a major failure and for compensation for any other reasonably foreseeable loss or damage. You are also entitled to have the goods repaired or replaced if the goods fail to be of acceptable quality and the failure does not amount to a major failure.

6.2 The Rheem warranty (set out above) is in addition to any rights and remedies that you may have under the Australian Consumer Law.

**RHEEM AUSTRALIA PTY LTD**, A.B.N. 21 098 823 511, [www.rheem.com.au](http://www.rheem.com.au)  
For Service Telephone 131 031 AUSTRALIA or 0800 657 335 NEW ZEALAND