

Sapphire / Neo (RIB23)

Zero Clearance Box assembly (R2340)

Item	Qty.	Description
1	1	ZC box base
2	2	ZC box side
3	1	ZC box top
4	1	ZC box rear
5	1	ZC spigot guide plate
6	2	Guide rail flue adaptor
7	1	Air duct outlet gasket
8	1	Spigot top assembly
9	1	Spigot rear
10	2	Edge protector white
11	31	Screw 8x10 AB zinc
12	2	Rivet pop plain 73 AS 4.2

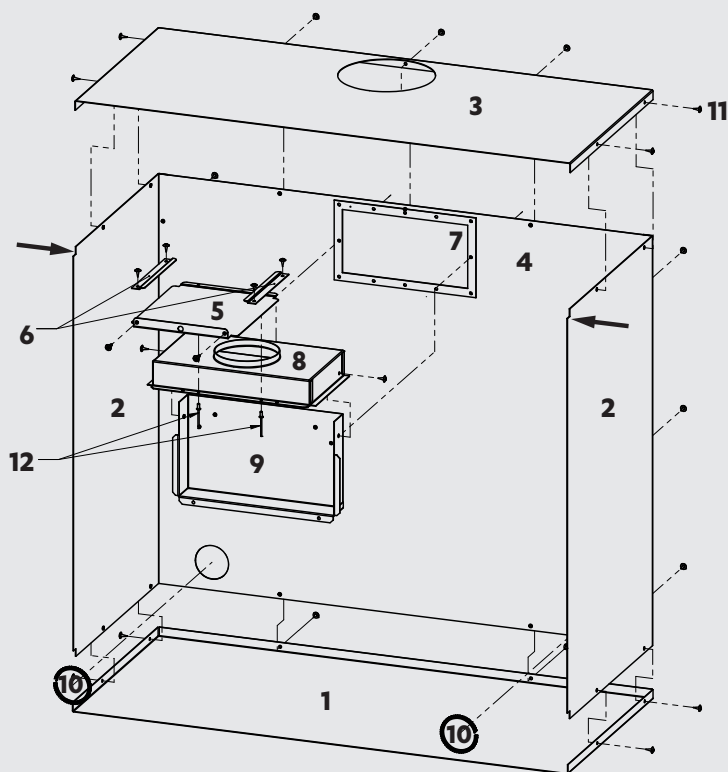

Important

To ensure the spigot assembly lines up correctly inside the enclosure and that the appliance is installed flush, the front edge of the zero clearance box should sit flush with the front edge of the cladding surface.

The drywall drops down to the level indicated by the two arrows either side of the box.

Before installation:

- Unpack the assembly and check for damage—DO NOT install any damaged items
- Check all components have been supplied
- Read these instructions to get an overview of the steps required before starting the installation

Failure to follow these instructions could cause the appliance to malfunction. This could result in serious injury and property damage.

General information

All dimensions are in mm.

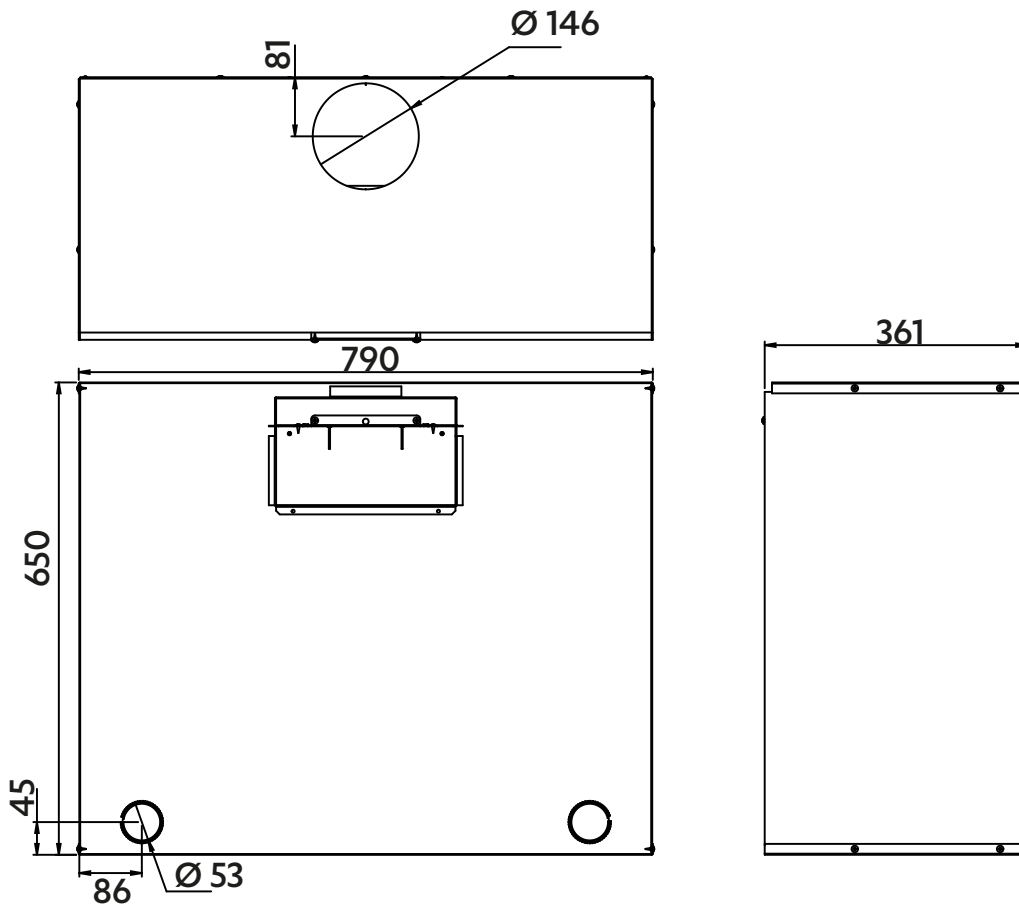

Assembly

1. Rivet the spigot guide to the spigot assembly

Assemble flue spigot, and rivet from the underside, the spigot guide plate provided in the zero clearance box kit to the spigot assembly.

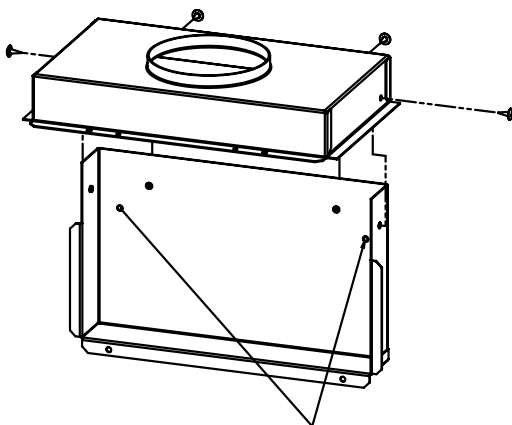

When this spigot is used with the zero clearance box these dimples are to be drilled at $\text{Ø} 3.2$

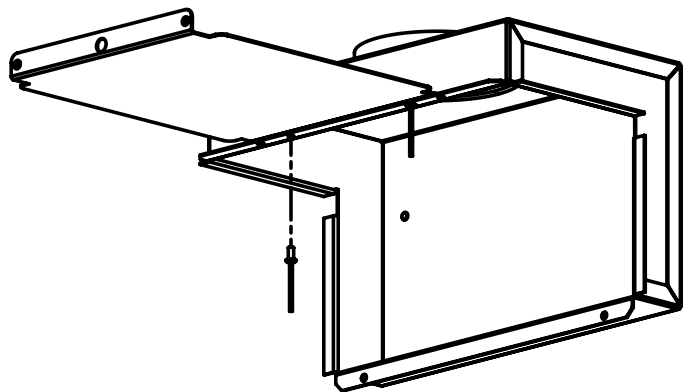

Assembly

2. Assemble base, sides and rear panel of zero clearance box

Lie the base panel on the floor and using the screws provided in the assembly pack, screw the side panels to the base and then attach the rear panel.

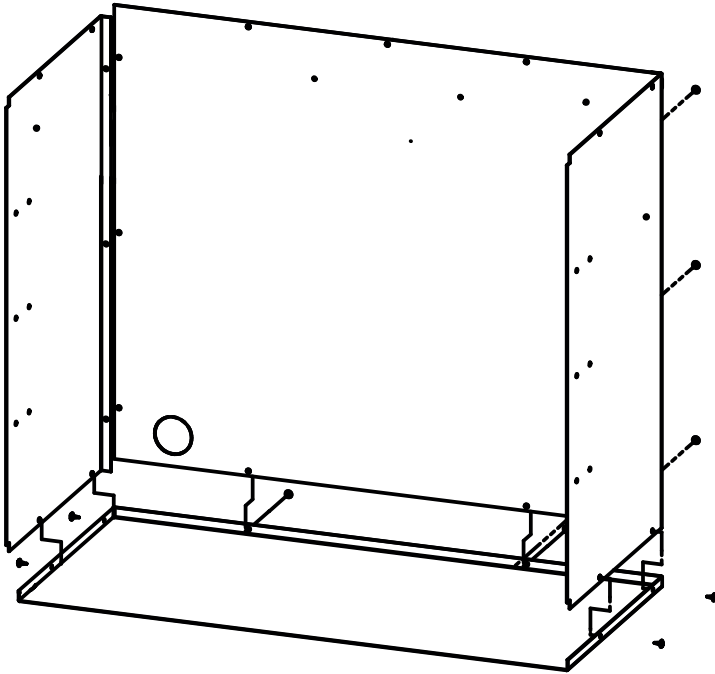

3. Attach full spigot assembly and top panel

Drill out the two 3.3 mm holes in the spigot where the two dimples are located. Screw the full spigot assembly to the back panel of the zero clearance box (through the back of box) and attach the top panel.

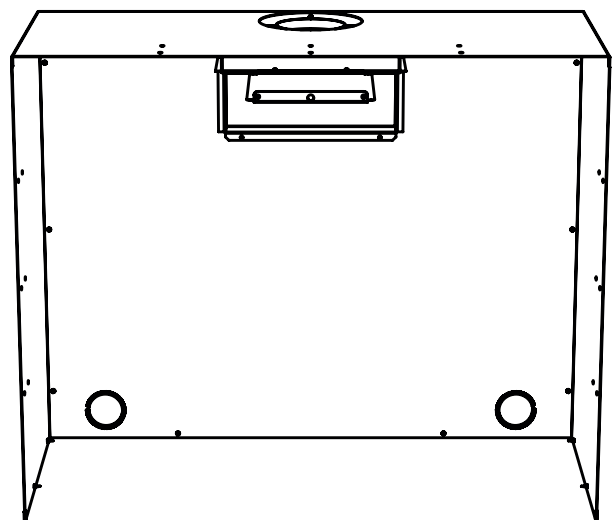
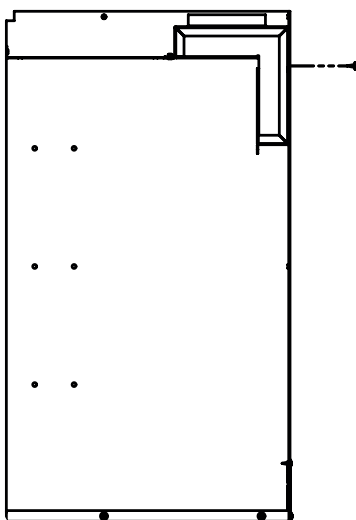

Assembly

4. Slide into the enclosure and secure

Slide the assembled zero clearance box into the enclosure and fix the top and sides to the enclosure. There are two sets of screw holes, the set you use will be dependent on the cladding thickness. The zero clearance box **MUST BE** installed flush with the cladding surface to ensure alignment of the flue.

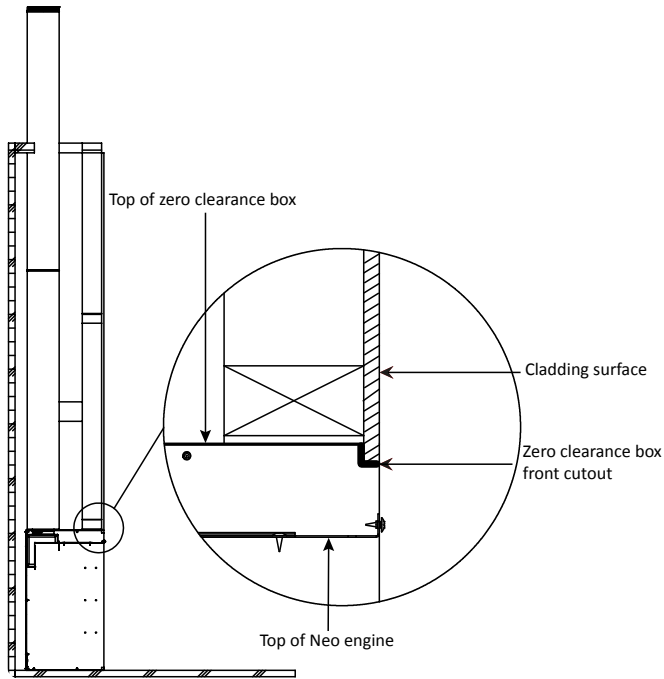

5. Apply edge protector

Apply white edge protectors provided in the assembly pack to the gas and electrical access holes.

6. Guide rails

Guide rails (number 6 on front page) need to be attached to the top of the Neo engine as shown.

