

Rinnai

Installation guide

Neo

RIB2312N / RIB2312L

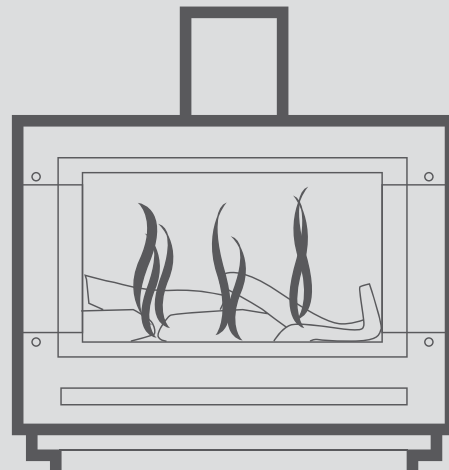
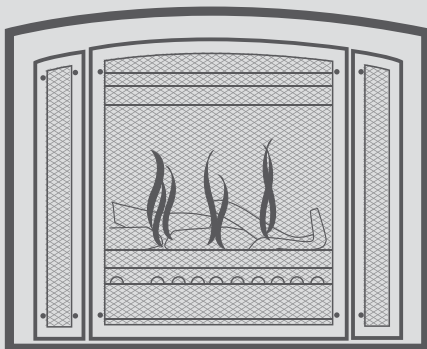
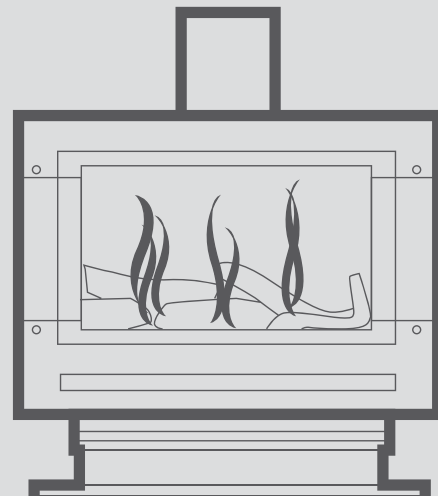
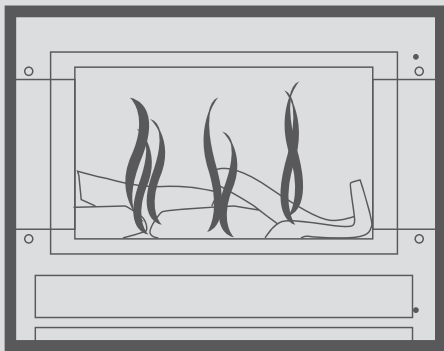

Important:

Appliance must be installed with a Rinnai approved flue system.

This appliance shall be installed in accordance with:

- Manufacturer's installation instructions
- AS/NZS 5601 Gas Installations
- AS/NZS 5263 Gas appliances standards

Installation, servicing and repair shall be carried out only by authorised personnel.

Warning

Improper installation, adjustment, alteration, service or maintenance can cause property damage, personal injury or loss of life.

For more information about buying, using, and servicing of Rinnai appliances call: 0800 RINNAI (0800 746 624).

Rinnai New Zealand Limited
105 Pavilion Drive, Mangere, Auckland
PO Box 53177, Auckland Airport, Auckland 2150

Phone: (09) 257 3800
Email: info@rinnai.co.nz
Web: www.rinnai.co.nz
www.youtube.com/rinnainz
www.facebook.com/rinnainz

contents:

Checklist.....	4
Neo specification	5
Inbuilt dimensions (mm)	6
Freestanding dimensions (mm)	7
Gas supply and connection	8
Electrical connection	9
Enclosure dimensions for inbuilt models	10
Mantels and surrounds - inbuilt models only	11
Clearances from combustibles.....	12
TV installation.....	14
Masonry installation	16
Inbuilt mock chimney.....	18
Freestanding installations	20
Log set and granule pack installation.....	22
Inner frame and control panel.....	24
Commissioning	25
Outer frame and dress guard	27
Flame pattern	28
Customer handover	28
Wiring diagram.....	29
Flueing.....	30

Checklist

Engine: Masonry installations

1. Rinnai Neo heater (engine)
2. Outer frame (standard or classic)
3. Glass outer dress guard—standard frame
Mesh dress guard—classic frame (inbuilt models)
4. Inner frame
5. Log set and granule pack (inside appliance)
6. Semi rigid stainless steel gas pipe
7. Flared brass adaptor $\frac{5}{8}$ " UNF - $\frac{1}{2}$ " BSPT
8. Foam sealing strip
9. Operation and installation guides

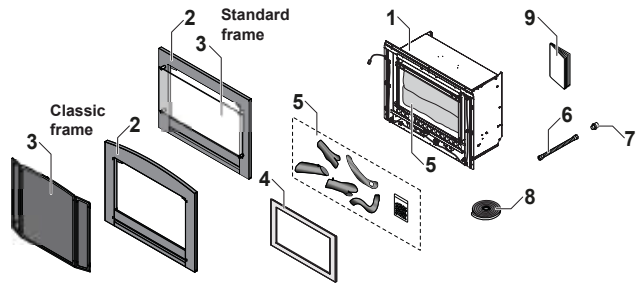

Inbuilt mock chimney installations

- A. Engine set (see above)
1. Spigot adaptor
2. Spigot guide panel
3. Spigot guide rails
4. Zero clearance box top panel
5. Zero clearance box rear panel
6. Zero clearance box left and right panels
7. Zero clearance box base panel
8. Hardware pack

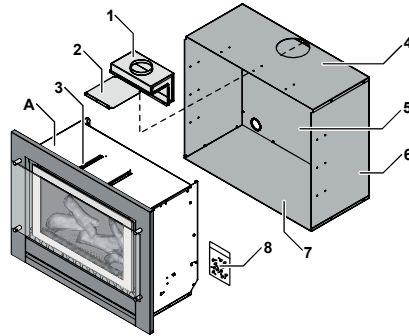

Freestanding console installations

- A. Engine set (refer masonry installation)
1. Spigot adaptor
2. Console top panel
3. Console right side panel
4. Console left side panel
5. Console rear panel
6. Console pillar
7. Hardware pack

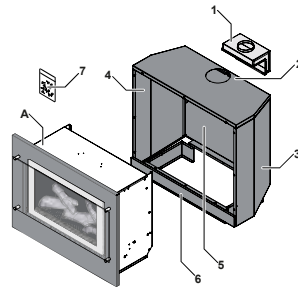

Freestanding plinth installations

- A. Engine set (refer masonry installation)
1. Spigot adaptor
2. Plinth top panel
3. Plinth right side panel
4. Plinth left side panel
5. Plinth rear panel
6. Plinth pillar
7. Plinth base
8. Hardware pack

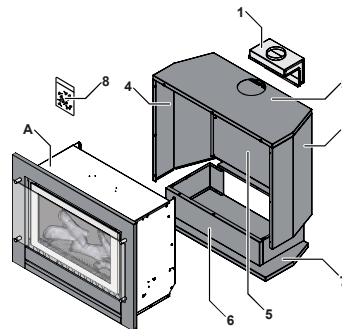

Infra-red remote control

Infra-red remote control (batteries inserted).
Remote comes as standard and will come with
the Neo engine.



Neo Specification

Natural draft burning log effect inbuilt gas fire with glass front and convection fan. Different frame options available.

Specification summary

Input	= 14-30 MJ/h*
Output	= 2.98-6.94 kW*
Efficiency	= 80%
Heating area	= 69-107 m ² **
Gas type	= NG or ULPG

* Will vary according to gas type and flue configuration

** Will vary depending on geographical location in NZ

Suitability

- Inbuilt masonry
- Inbuilt mock chimney
- Freestanding

The Neo is not suitable for areas where painting is taking place, or in places such as hairdressing salons, where there may be fluff and dust, and where aerosols are used. The inbuilt Neo gas fireplace models are not designed to be built into bookcases.

Installation considerations

The Neo draws air for combustion from the room. Adequate ventilation must be calculated and provided by the gasfitter as per AS/NZS 5601.1.

Burn media

Driftwood log set comes as standard.

Convection fan

Fan forced 2-speed convection fan (low and high). Heat is distributed from the top of the appliance.

Data plate

Inside appliance on the front left hand side.

Gas connection

½ " BSPT (flexi). The gas supply terminates inside the heater at the lower front right hand side of the appliance.

Ignition

Continuous spark electronic ignition.

Noise level

37-45 dB(A)

Flue (masonry)

The Neo must be installed with a Rinnai flexiliner flue (Ø 100 mm).

Flue (mock chimney and freestanding)

Appliance must be installed with a Rinnai flue system. Inner 100 mm, outer 150 mm.

Power consumption and electrical supply

High	= 50 W
Standby	= < 3 W

Comes with a 1.5 m power cord and 3-pin plug. The standard electrical connection is to the rear left of the appliance, but can pass through the left or right by removing the knockout tab from the bottom edge of the front panel.

Safety devices

Overheat switch, electrical fuse, and flame failure sensing system.

Temperature control

Once the unit is turned on the infra-red remote* is used to control the flame height and heat output.

If the remote is not used the Neo will automatically modulate between the burner settings to maintain the default set temperature of 22 °C.

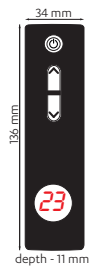

* Temperature sensor is located in the bottom of the remote.

Weight

60 kg

Inbuilt dimensions (mm)

includes the frame

Neo Inbuilt masonry

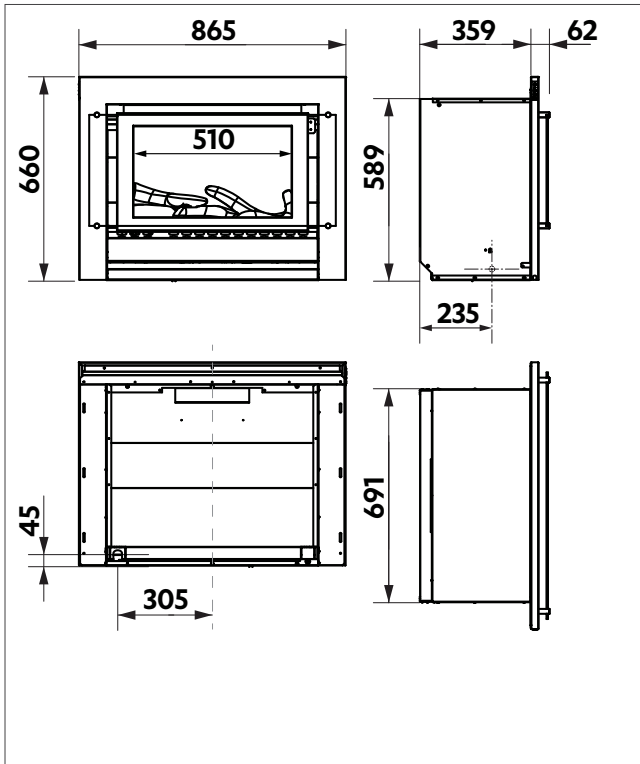

Neo Inbuilt mock chimney

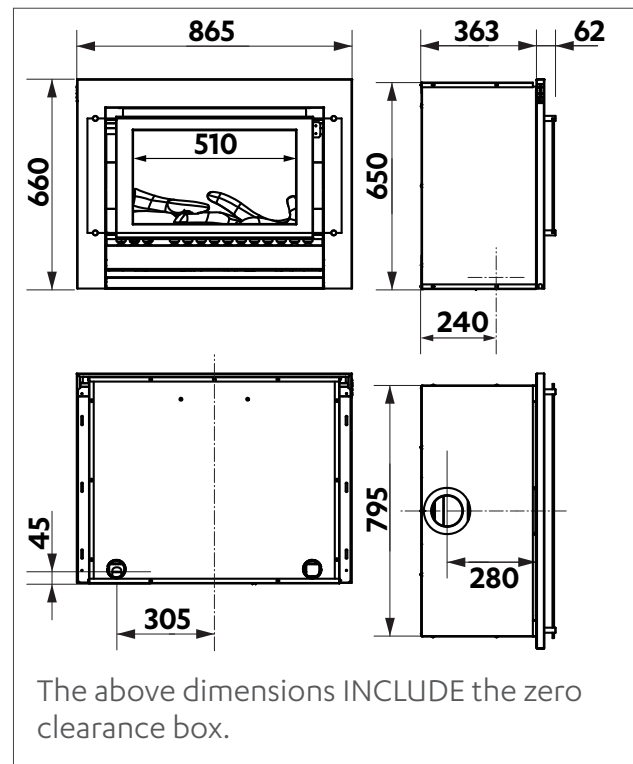

Neo Inbuilt Premium Classic

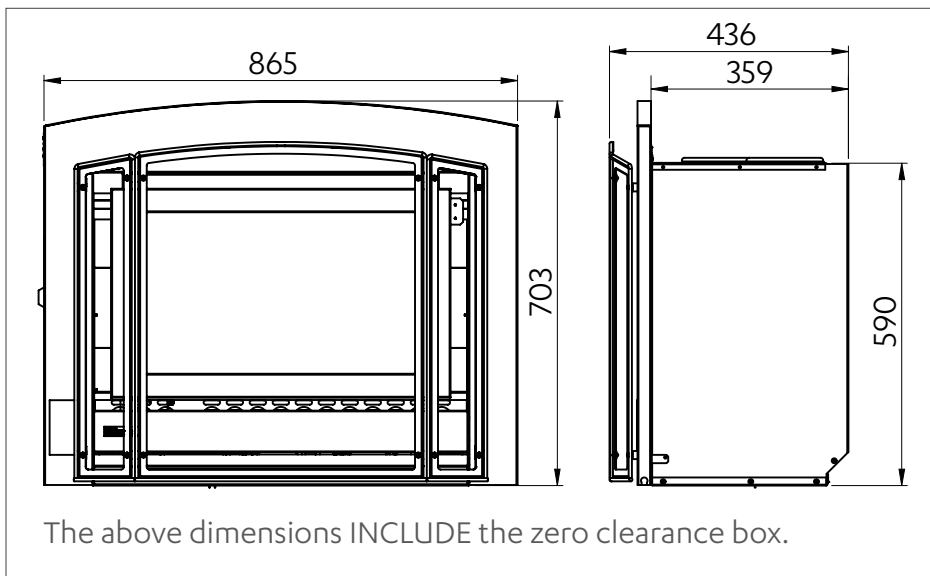

Freestanding dimensions (mm)

includes the frame

Freestanding console

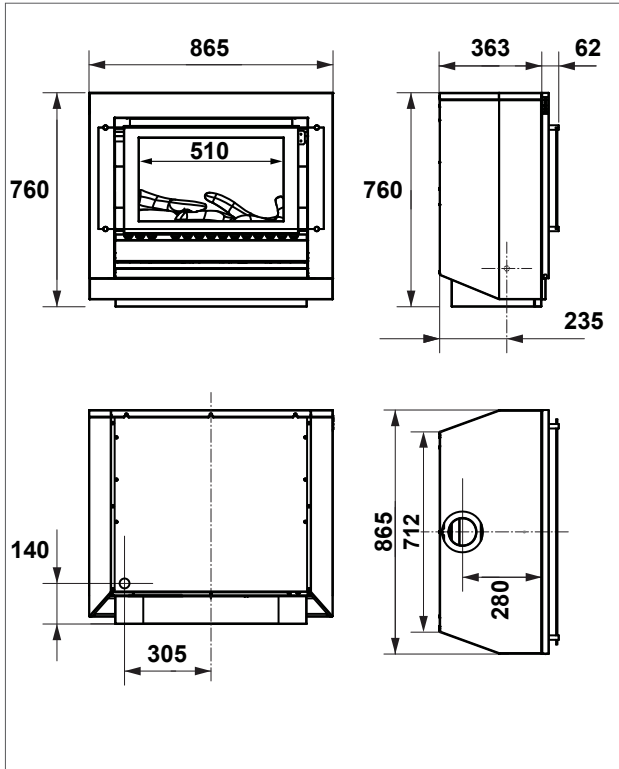

Freestanding plinth

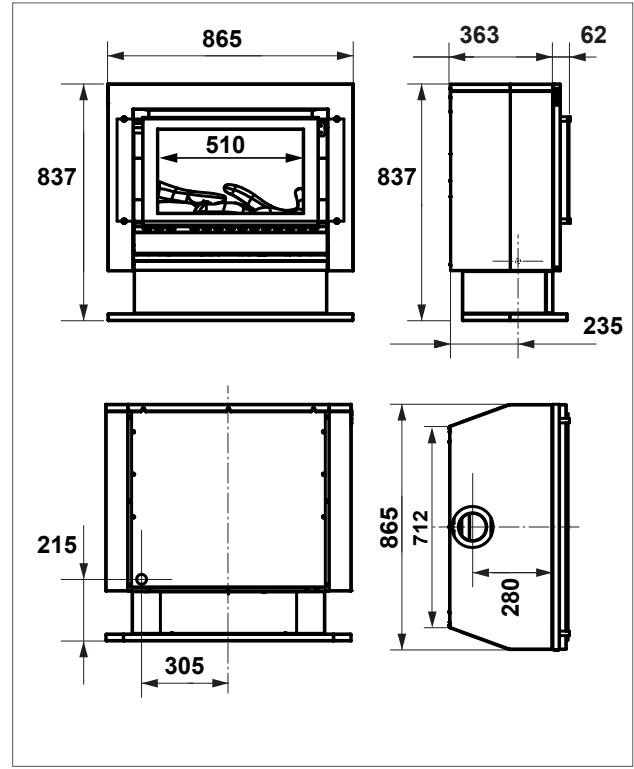

Gas supply and connection

Gas pipe sizing must consider the gas input to this appliance as well as all other gas appliances in the premises. The gas meter and regulator must be specified for the total gas rate. An approved sizing chart such as the one in AS/NZS 5601.1 should be used. The gas supply termination is inside the heater and enters through the rear of the appliance.

Gas supply location

1. Mark off the location for the vertical centre line of the heater enclosure.
2. To the right of the vertical centre line, mark off the vertical **2** and horizontal **3** locations for the gas supply penetration.

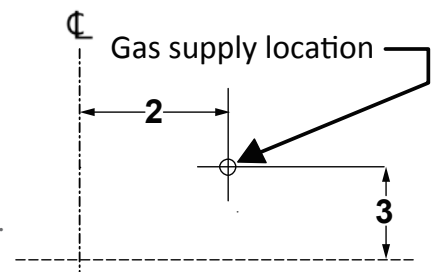

	INBUILT		FREESTANDING	
	Masonry	Mock chimney	Console	Plinth
②	305 mm to right of the appliance centre line	305 mm to right of the appliance centre line	305 mm to right of the appliance centre line	305 mm to right of the appliance centre line
③	35 mm from base of enclosure	35 mm from base of enclosure	140 mm from floor level	215 mm from floor level
④	Terminate 230 mm from front of enclosure	Terminate 230 mm from front of enclosure	Terminate at wall, clearance plus 155 mm	Terminate at wall, clearance plus 155 mm

STEP 1 Inbuilt installations

The length of the gas supply termination is measured from the front of the enclosure.

Freestanding installations

The length of the gas supply termination is measured from the **back** of the heater plus 155 mm.

STEP 2

Installer to terminate to suit, and fit supplied gas connection ⑤. Leak test the joint between the flexible gas connection and termination.

Gas connection

Firmly grasp the stainless steel flexi pipe and bend to line up with the gas control valve inlet, then attach the pipe to the gas control valve and tighten.



The use of a rubber hose for any gas connection to a fixed appliance is **NOT** authorised by the manufacturer.

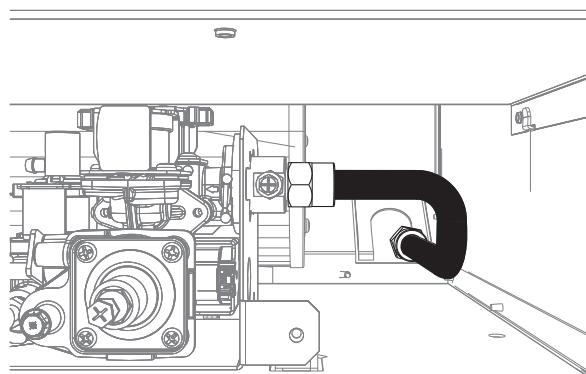

Electrical connection

The Neo is supplied with a power cord (length 1500 mm) and a 3-pin plug. The standard electrical connection passes through the rear panel, but can also pass through the left or right hand side of the unit by removing the knockout tab from the bottom edge of the front panel. If changing the electrical position use the rubber grommet from the rear of the appliance for cable protection.

The connection is either direct wired* or connected to a power point within the cavity. This must be connected to a dedicated 240 V, 10 A earthed power point. The electric isolation switch must be accessible after the appliance has been installed.

The heater must not be located immediately below a socket outlet (potential fire hazard).

The power cord is not fire rated and should not come into contact with the unit. If the power cord is damaged, it must be replaced by a licensed tradesperson. This must be a genuine replacement part available from Rinnai.

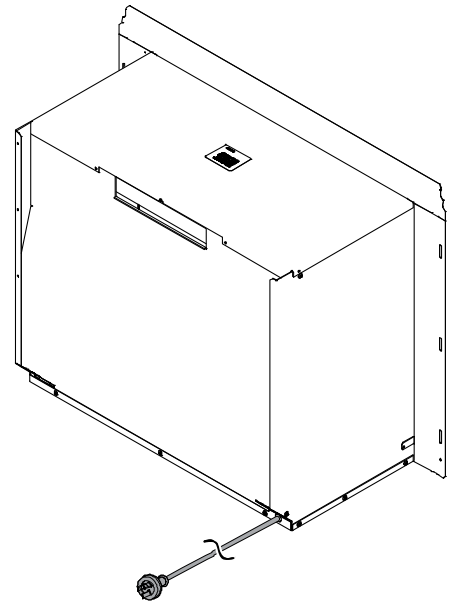

Using existing externally mounted power points on inbuilt installations

If you already have an existing power point outside the enclosure, you can redirect the power cord and plug through the LHS or RHS of the front panel. With the frame removed redirect the cord and plug (with the grommet), underneath the unit and to the front (left or right).

Remove the pre-punched metal knock-out located in the lower left or right edge of the frame. Refit the cord and plug to the frame, ensuring the grommet is fitted to the metal knock-out. Excess cord may be left in the cavity below the unit—DO NOT coil excess cord.

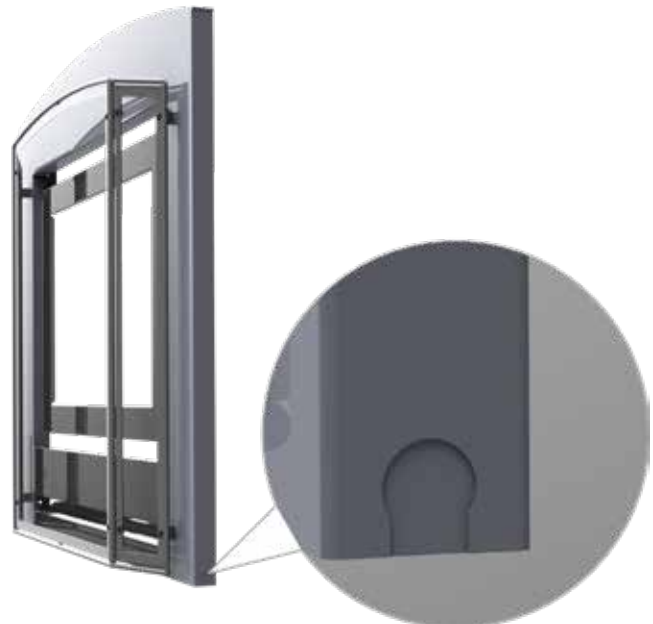

Electrical knock-out position on a Neo frame—knock-out is on both sides of the frame.

* Consult a qualified electrician if direct wiring is required as it must comply with AS/NZS 5601 and AS/NZS 3000 and other relevant local regulations

Enclosure dimensions for inbuilt models

The main points governing location are flueing and warm air distribution. The enclosure dimensions provided are critical to the installation of this appliance and must be adhered to.

The heater must be positioned on a flat level surface that allows free movement of the appliance.

Inbuilt masonry installations

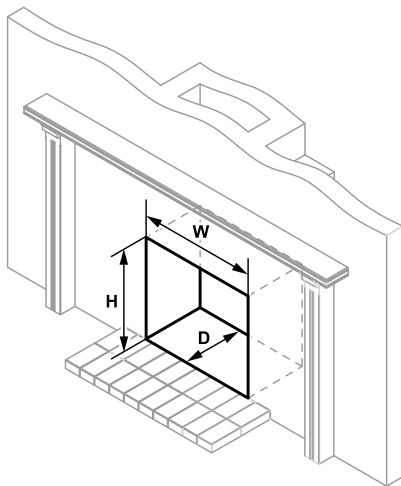

Inbuilt masonry	
W-width	695 mm
H-height	600 mm
D-depth	370 mm

Use a slurry of sand and cement to level the base as required.

Inbuilt mock chimney installations

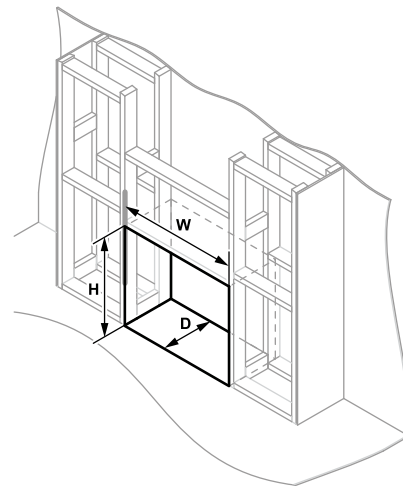

Inbuilt mock chimney	
W-width	800 mm
H-height	655 mm
D-depth	370 mm

The zero clearance box needs to be supported within the enclosure. Either construct a base using board with supporting joists or support with the frame itself—must be capable of supporting a minimum of 1.5 times the weight of the appliance.

IMPORTANT

The total cavity depth **MUST** also include the thickness of the external cladding as the zero clearance box **MUST BE** installed flush with the cladding surface to ensure alignment of the flue.

Mantels and surrounds - inbuilt models only

Combustible mantels and surrounds require clearance from the unit to minimise the risk of fire. Mantels and surrounds, made of combustible materials such as wood, are allowed providing they are outside the minimum clearances shown.

The Neo gas fireplace is not designed to be built into bookcases.

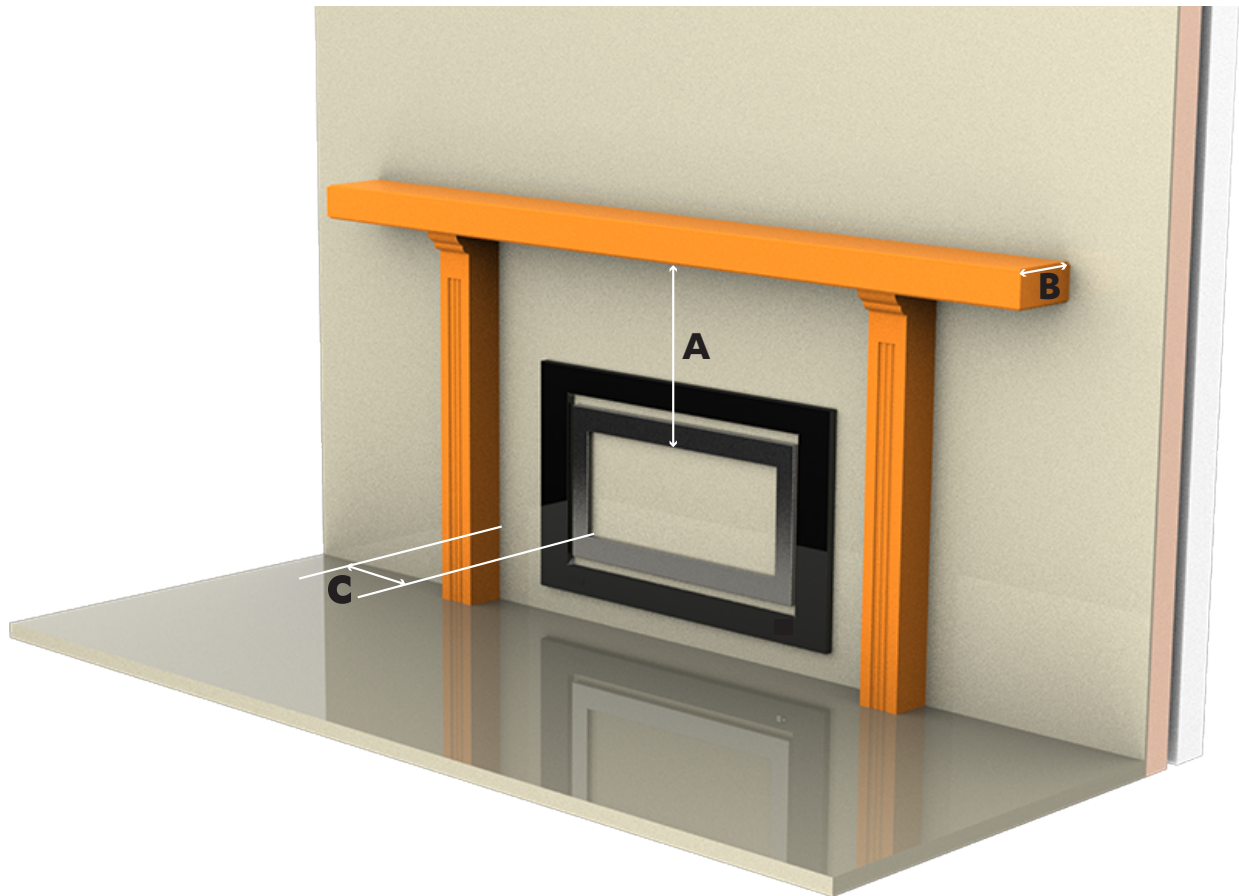

A Mantel needs to be a minimum of 400 mm away from the edge of the inner glass.

B Maximum mantel depth at 400 mm (A) is 250 mm.

C Surround needs to be a minimum of 400 mm away from the edge of the inner glass.

For every 50 mm of added mantel depth there must be an additional 100 mm of clearance from the edge of the inner glass.

For example:

MANTEL DEPTH	A: CLEARANCE REQUIRED
300 mm	500 mm
350 mm	600 mm
400 mm	700 mm

Clearances from combustibles

The clearances listed below, measured from the **edge of the inner glass**, are minimum clearances unless otherwise stated.

While the heater is operating

The appliance must not be installed where curtains or other combustible materials could come into contact with the heater. The 400 mm side clearance includes side walls.

Floor protection

Heat from this fire may over time affect the appearance of some materials used for flooring, such as, carpet, vinyl, cork or timber. This may be amplified if the air contains cooking vapours or cigarette smoke. To avoid this occurring, it is recommended that a mat be placed in front of this appliance.

Hearths

A hearth is not necessary, but can be used for decorative purposes or protection of sensitive flooring. A hearth, if installed, must not obscure the front of the fire.

TV installation above the fireplace

The Neo has a fan that distributes warm air from the top of the appliance out into the room. As warm air is dispersed outwards, as opposed to directly upwards, installation of a TV may be an option.

Generally the bottom of the television recess should be at least 400 mm above the fire. Please check with the television supplier to check clearances. Some television manufacturers have warranty conditions that state a television is not to be installed above a fireplace.

For further information refer to p. 14.

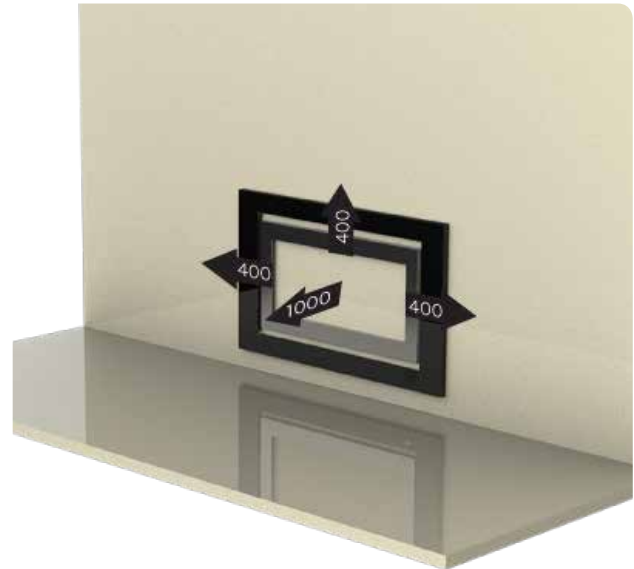

Neo Inbuilt clearances



Neo Freestanding clearances

The below diagrams are to assist people who are determining the clearance area around the Neo without having the unit on site.

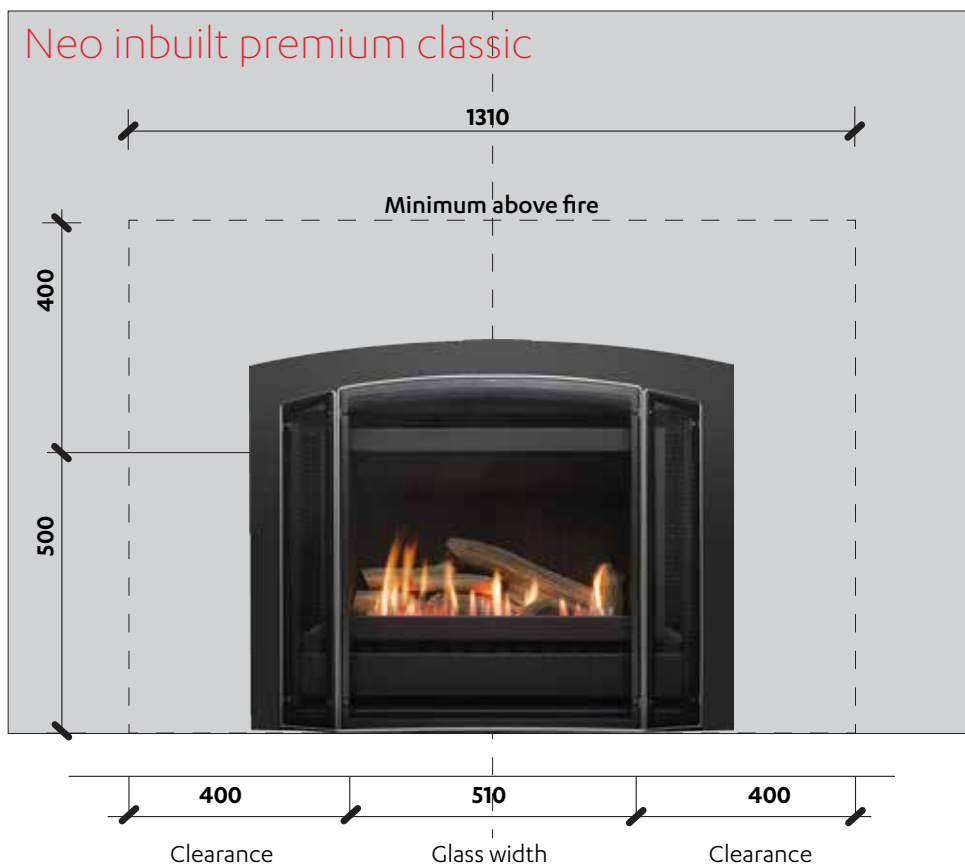
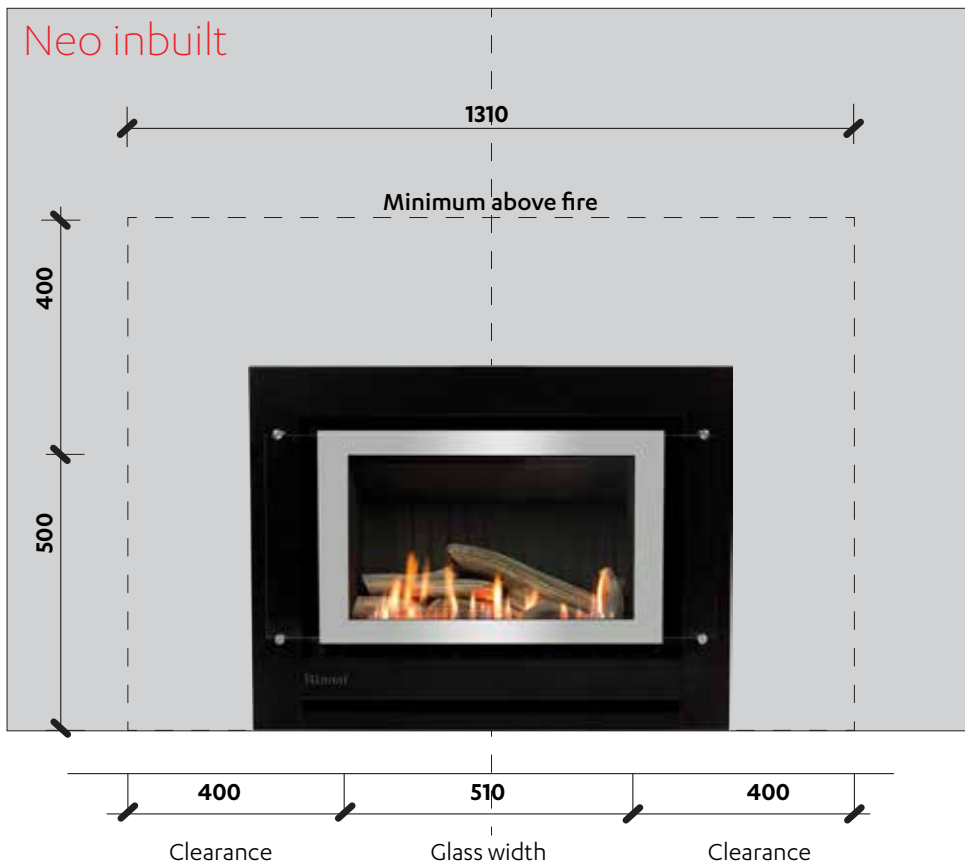

TV installation

The Neo has a fan that distributes warm air from the top of the appliance out into the room. As warm air is dispersed outwards, as opposed to directly upwards, installation of a TV may be an option.

The diagram shows recommended clearances when installing a TV directly above the Neo, or into a recess. All dimensions are in millimetres.

400 mm dimension

The 400 mm dimension is the minimum clearance required to a mantel. The image adjacent shows the dimension from the edge of the frame, in the case of the Neo the 400 mm dimension is to be taken from the edge of the inner glass.

Always check with the TV manufacturer

It is up to the owner to check the TV installation with the TV manufacturer—some have warranty conditions that state a TV is not to be installed above a fireplace.

Rinnai does not accept any responsibility for damage to a TV resulting from the use of this information.

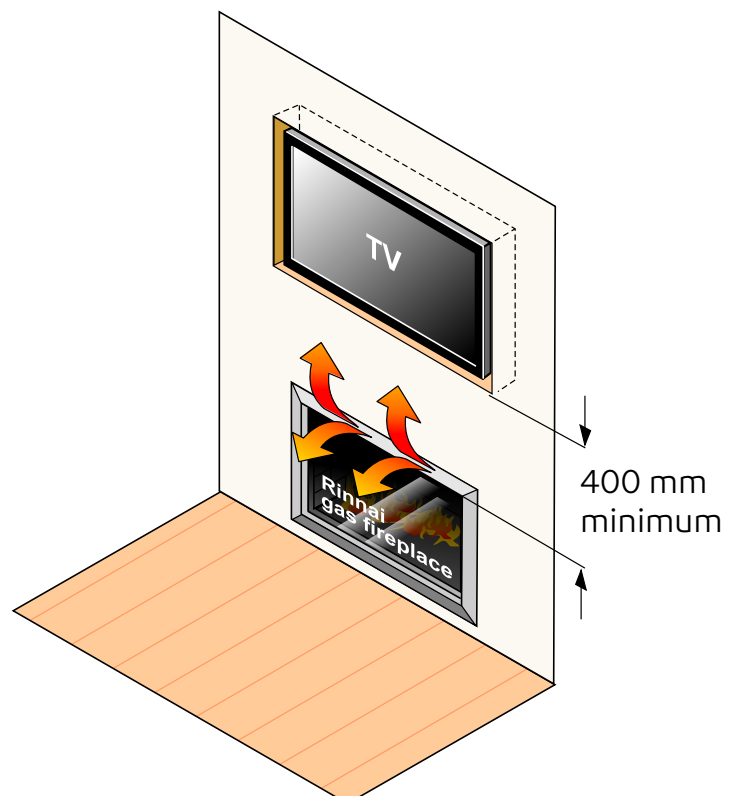
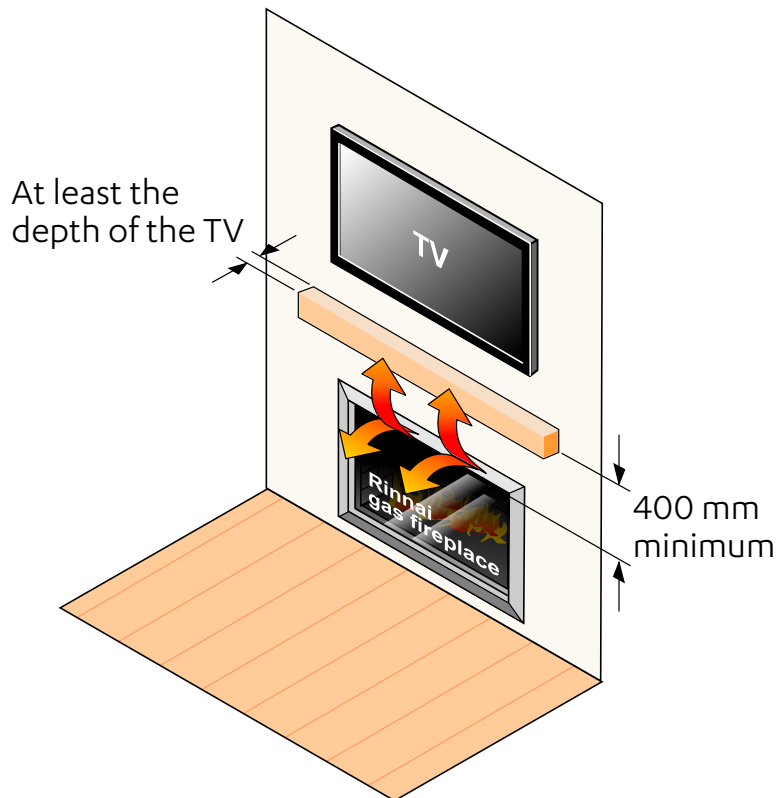

Installation

Installation, servicing and repair shall be carried out only by authorised personnel.

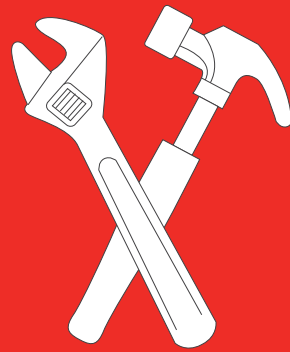

Masonry installation

- 1 Prepare the site**

Ensure the enclosure meets the dimension requirements and check the gas and electrical supplies have been prepared according to information in this guide.
- 2 Unpack the engine**

The Neo engine is supplied in one carton. Check for damage and ensure you have the correct gas type before starting. Do not install if any damage is evident.
- 3 Install the flue**

Install flexiliner flue*, refer following page and p. 32 for an overview of how the flue is assembled and connected to the unit.

* As per AS/NZS 5263.0:2017 2.15.2.3, do not use an unlined masonry chimney as the flue for this appliance.
- 4 Prepare the engine**

Attach the adhesive backed foam sealing strip supplied to the rear face of the front assembly mounting panel, approximately 30 mm from the top edge. The foam seal forms a seal between the unit and the fireplace brickwork. If a seal cannot be formed then another means of sealing must be used—non-combustible insulation or heat resistant silicone.
- 5 Connect the flue adaptor**

Connect the flue adaptor to the flexiliner flue.
- 6 Position the engine and connect the electrical supply**

Place the Neo engine in front of the fireplace enclosure. Use a panel of cardboard packaging underneath the engine to minimise damage to the floor. Connect the electrical supply.
- 7 Insert the Neo into the fireplace**

Move the heater into the fireplace ensuring the gas supply pipe and fittings feed into the rear access hole. Connect the flue.
- 8 Connect the gas supply**

Refer p. 8.
- 9 Leak test**

Leak test all appliance connections. When finished remove any residue with a rag, Prevent any soapy solution coming into contact with the electrical components.
- 10 Secure**

Fasten the heater to the fireplace using appropriate fasteners (not supplied), using the three holes across the top and at least two holes on each side.
- 11 Complete the installation**

Refer p. 22-28.

4. Preparing the engine

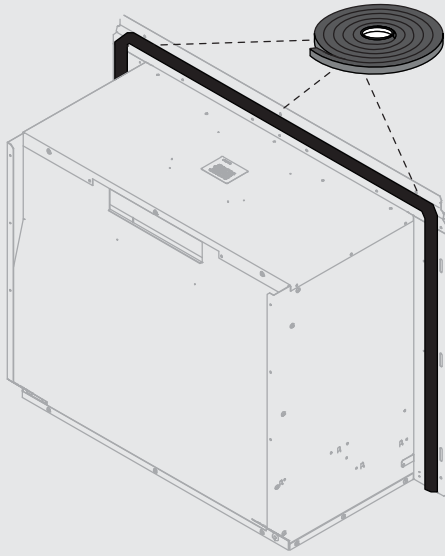

7. Inserting the engine into the fireplace.

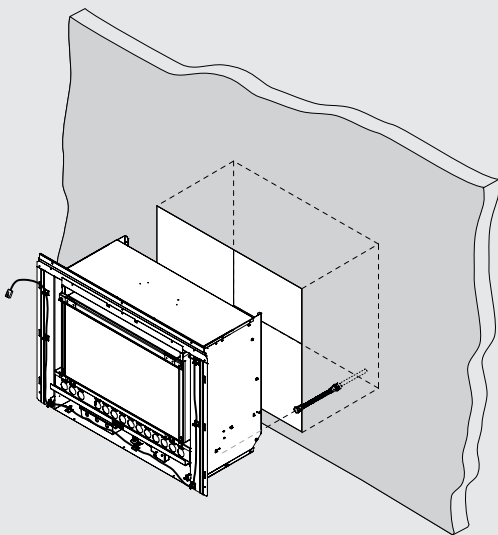

10. Securing the heater

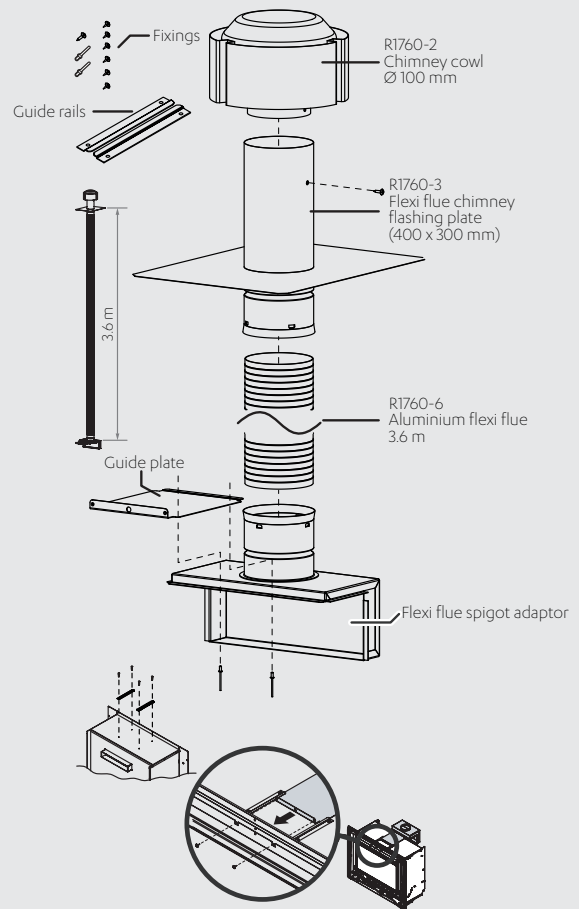
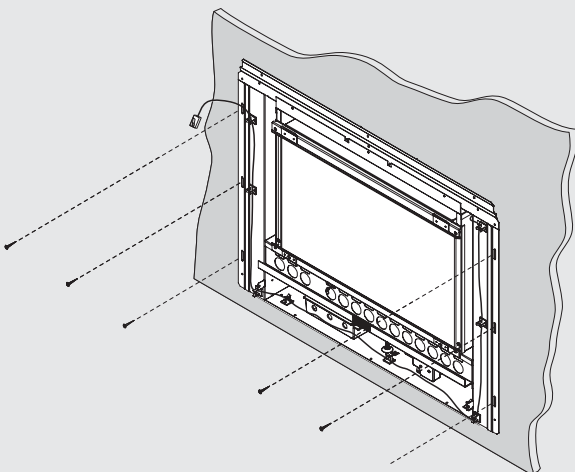

Attaching the flexiliner flue to the unit

1. Attach the guide rails to the heater using the predrilled holes and four screws.
2. Align the guide plate with the guide rails and slide the flue assembly forward until the front tab of the guide plate is fully forward and against the rear of the flange at the top of the heater.
3. Ensure the guide plate is securely fastened with two screws to the flue access plate.

Inbuilt mock chimney (zero clearance installation)

- 1 Prepare the site**

Ensure the enclosure meets the dimension requirements and check the gas and electrical supplies have been prepared according to information in this guide.

Ensure there are no studs, noggins, ceiling joints, wiring or other obstructions within the wall or ceiling cavity where the flue is to be located.
- 2 Assemble the zero clearance box**

Refer separate assembly instructions included with the zero clearance box.
- 3 Fit the zero clearance box**

Slide assembled box into the cavity, ensuring the gas and electrical supplies are accessible.
- 4 Install the flue**

Install the flue kit and/or individual flue components.
- 5 Unpack the engine**

The Neo engine is supplied in one carton. Check for damage and ensure you have the correct gas type before starting. Do not install if any damage is evident.
- 6 Prepare the engine**

Attach the flue guide rails, supplied with the zero clearance box, to the top of the unit using the four predrilled holes and screws supplied.
- 7 Install cladding**

Before installing the Neo ensure the cladding for the front of the enclosure has been fitted. The cladding **MUST BE** installed flush with the zero clearance box. Failure to do this will cause alignment problems with the flue.
- 8 Connect the flue adaptor**

Connect the flue adaptor* to the engine by aligning the guide rails with the guide plate* of the flue adaptor. Slide the flue adaptor in until the guide plate is fully home against the rear of the flange at the top of the heater.

* Supplied with the zero clearance box
- 9 Position the engine and connect the electrical supply**

Place the Neo engine in front of the fireplace enclosure. Use a panel of cardboard packaging underneath the engine to minimise damage to the floor. Connect the electrical supply.
- 10 Insert the unit into the enclosure**

Move the engine into the zero clearance box ensuring the gas supply and pipe fittings feed into the rear access hole. Align the guide rails with the guide plate and slide in the engine until the guide plate is fully home against the rear frame mounting panel.
- 11 Connect and secure the flue**

The weight of the flue should not be supported by the appliance, it should be self-supporting. Supporting the flue is usually completed during the framing stage with flue supports or straps within the cavity.

Replace the flue access plate and secure the guide plate of the flue adaptor to the flue access plate with the two screws supplied. Secure access plate to the engine.

next
page

12 Connect the gas supply

Refer p. 8.

13 Secure engine to the enclosure

Fasten the engine to the enclosure using appropriate fasteners (not supplied), using the three holes across the top and at least two holes on each side, refer p. 17.

14 Leak test

Leak test all appliance connections. When finished remove any residue with a rag, Prevent any soapy solution coming into contact with the electrical components.

15 Complete the installation

Refer p. 22-28.

Assemble and fit the zero clearance box

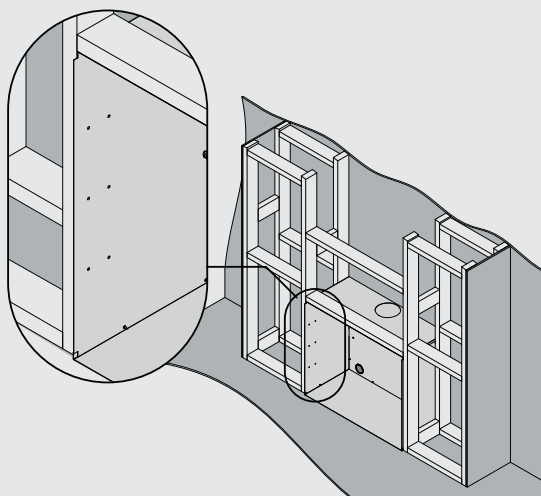
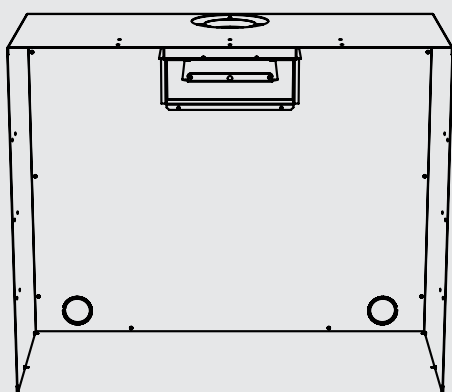

Prepare heater engine and fit cladding

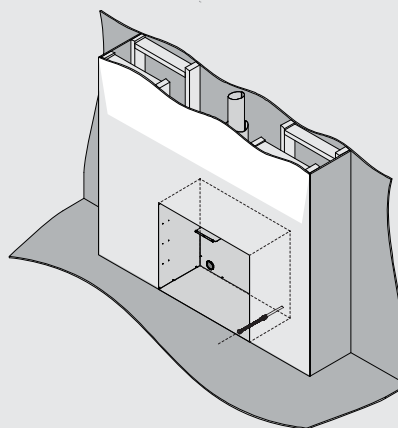
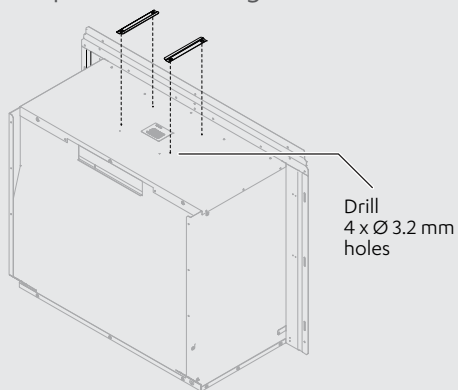

Align guide rails with the guide plate

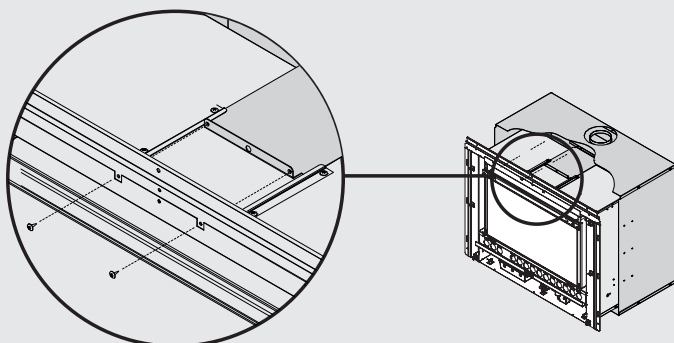

Freestanding installations

1

Prepare the site

Check the installation area has been prepared according to the gas and electrical supply requirements in this guide.

Ensure there are no studs, ceiling joints, wiring, or other obstructions within the ceiling cavity where the flue is to be located.

2

Install the flue

Install flue kit and/or individual flue components.

3

Unpack engine and freestanding kit

The Neo engine and freestanding kit are supplied in separate cartons. Check for damage and ensure you have the correct gas type before starting. Do not install if any damage is evident.

4

Assemble, position and secure the base assembly

Assemble the base assembly of the freestanding kit and place on the floor where the Neo is to be located. Using three fasteners (not supplied), secure the base assembly to the floor—this also acts as a seismic restraint.

5

Attach spigot adaptor and outer panels

Assemble the flue spigot.

Drill 4 x Ø 3.2 mm holes in the location dimples on the top rear of the Neo engine, then fit the flue spigot using the four self-tapping screws provided.

Fit the rear and side panels using the screws provided. You may need to elevate the engine approximately 100 mm off the ground to assemble the side panels.

Align the top panel tabs over the rear panel and fasten to the engine at the front and rear using the screws provided.

6

Fit heater to the base assembly

Lift the heater onto the base assembly ensuring the gas supply pipe and fittings feed into the rear access hole. Align the heater securing holes over the M5 root nuts and secure using the four screws provided. Two of the screws are located midway into the heater on the lower left and right edges.

7

Connect electrical supply

8

Connect the gas

Refer p. 8.

9

Leak test

Leak test all appliance connections. When finished remove any residue with a rag, Prevent any soapy solution coming into contact with the electrical components.

10

Complete the installation

Refer p. 22-28.

4 Fitting the base assembly

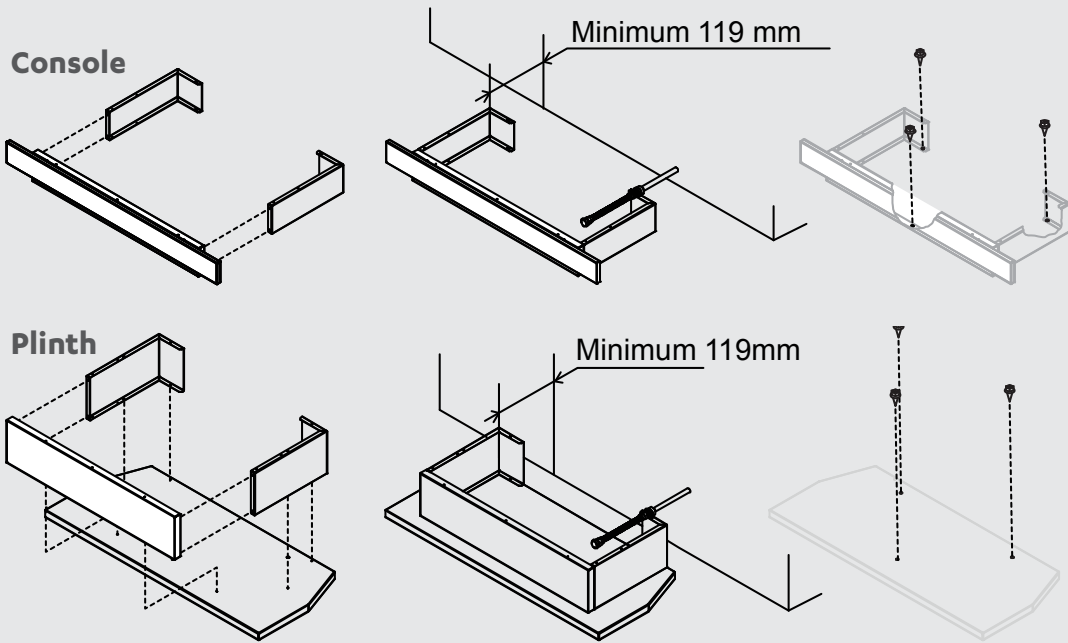

5 Attach spigot adaptor and outer panels

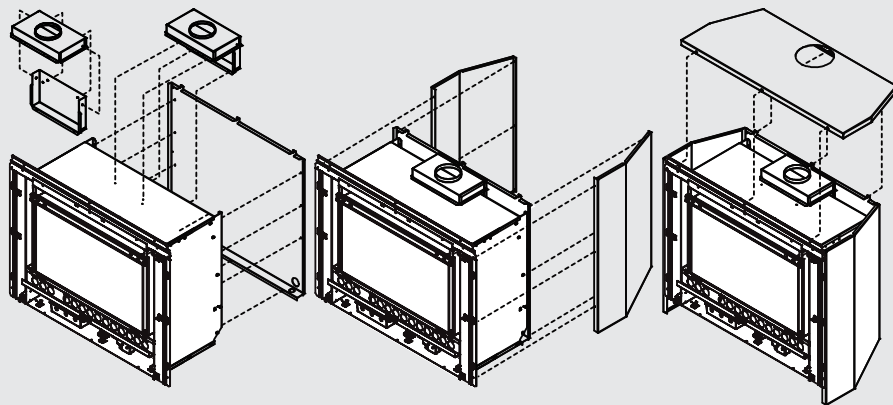

6 Fitting the heater to the base assembly

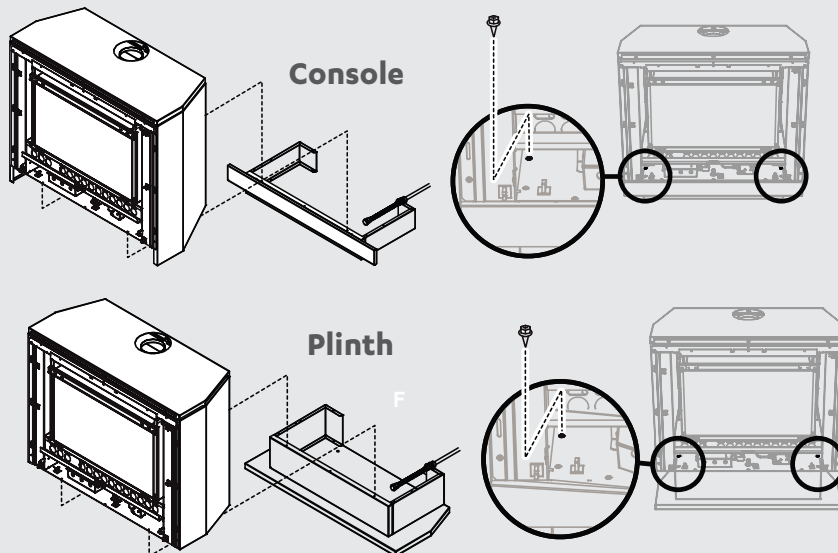

Log set and granule pack installation

The granule pack and log set, consisting of five log pieces, comes packaged inside the appliance. The glass retainer will need to be removed before installing the granules and log set. Use extreme care when handling the log pieces, they are made from a fragile material and will damage easily.



Use these instructions in conjunction with the log location guide attached to the glass of the Neo engine.



It is important to position the pieces in the order shown below. Incorrect placement can create carbon build-up and affect performance. Malfunctioning due to improper log placement is not covered by warranty.

The unit must never be used with broken logs or other burn media (except the Neo granules).

1. Check to ensure the ports of the main burner are clean and clear of any particles and all packaging.
2. Select the thicker 'Y' log and fit into position by lining up the two pin holes onto the two pins of the locating bracket that is fixed to the centre of the main burner.

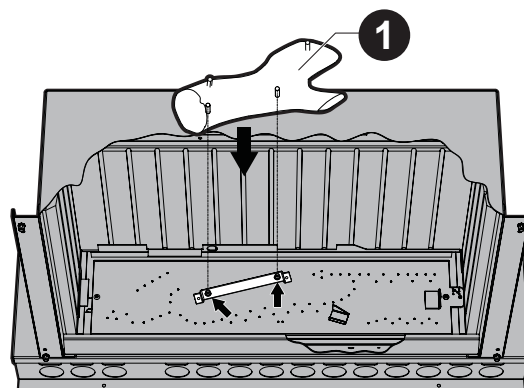
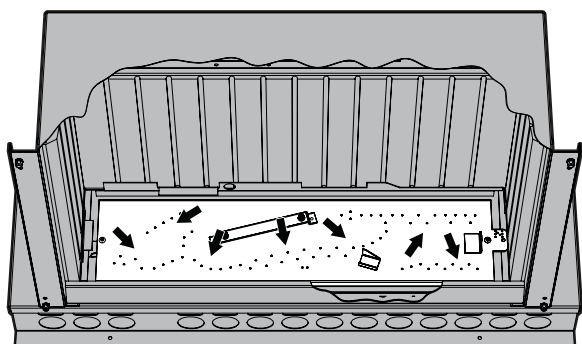

3. Select the short straight log with the single locating pin and place onto the metal tabs at the left and rear of the burner box—will touch the burner box walls when correctly positioned.

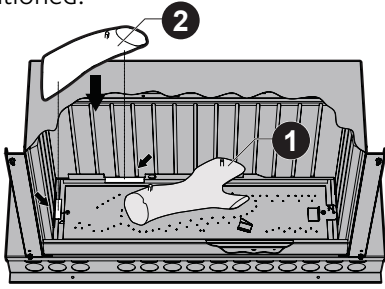

4. Select the thinner 'Y' log and fit into position by linking up the two pin holes onto the two pins of the first two logs. Ensure this log is seated all the way down until it touches logs 1 and 2.

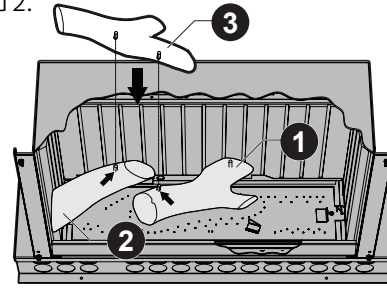

5. Select the longest log and line up the hole with the pin of log 1. When correctly located this log will be touching the burner box walls and resting on log 1.

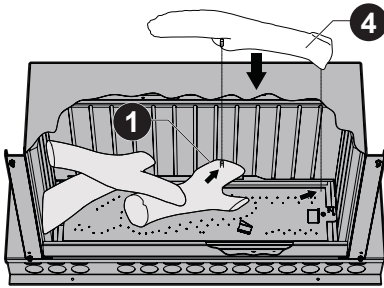

6. Locate the final bowed log and line up the hole with the pin bracket to the right of the burner, and locate the front of the log onto the stop bracket. When correctly positioned it will be touching both brackets, log 4, and the right burner box wall.

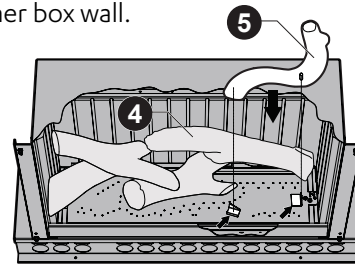

Granule pack installation



The granules as well as being added to create a more realistic log flame effect (they diffuse the gas flames through the burner ports) also assist in soot prevention and are CRITICAL to the heater operating correctly. Never pour the granules directly from the bag as dust particles from the bag may block the burner ports.

Natural gas installations

Place the granules evenly across the burner, use the whole pack.

ULPG installations

Carefully place 30 of the granules as close as possible to the front burner ports as shown on the diagram below. DO NOT cover any of the front right side ports. It's important this is done correctly as incorrect placement can cause high yellow flames (dirty combustion) that may cause sooting.

It is desirable that the flames touch the granules as this diffuses any 'candling' effect and enhances the realistic log burning look of the heater.

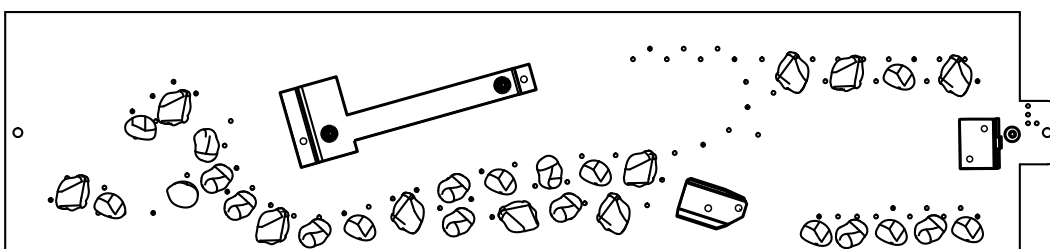

Inner frame and control panel



Before fitting the frame assembly ensure that it is not scratched or damaged. When placing the assembly down ensure it is placed on its lower edge or flat. If it is placed on its left or right edge the glass may slide out off the stand-off posts. If this should occur ensure that the silicon mounts are not dislodged when sliding the glass back into position.

Fit the inner frame

The inner frame (packed with the outer frame) is held in position by the return tabs on the top edge and by magnets on the bottom edge. Fit the inner frame to the heater engine by locating the over-folded edge over the two return tabs, then gently swing down the bottom edge onto the magnets.

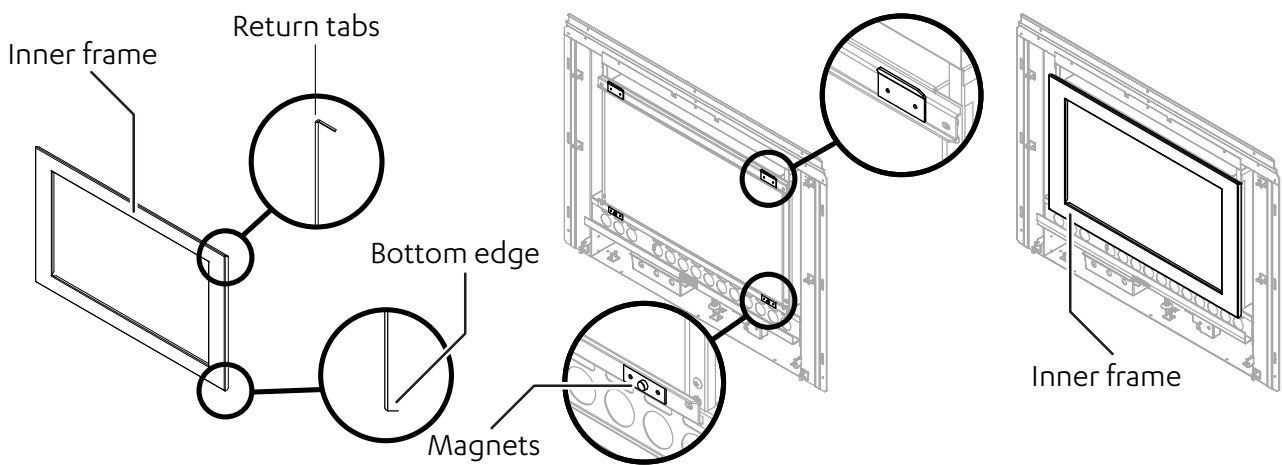

Connect the control panel

Position the outer frame close to the heater engine and connect the RJ45 plug into the socket located on the back of the frame on the top left hand corner—this connects the push button control panel via a communication cable to the heater engine control box.

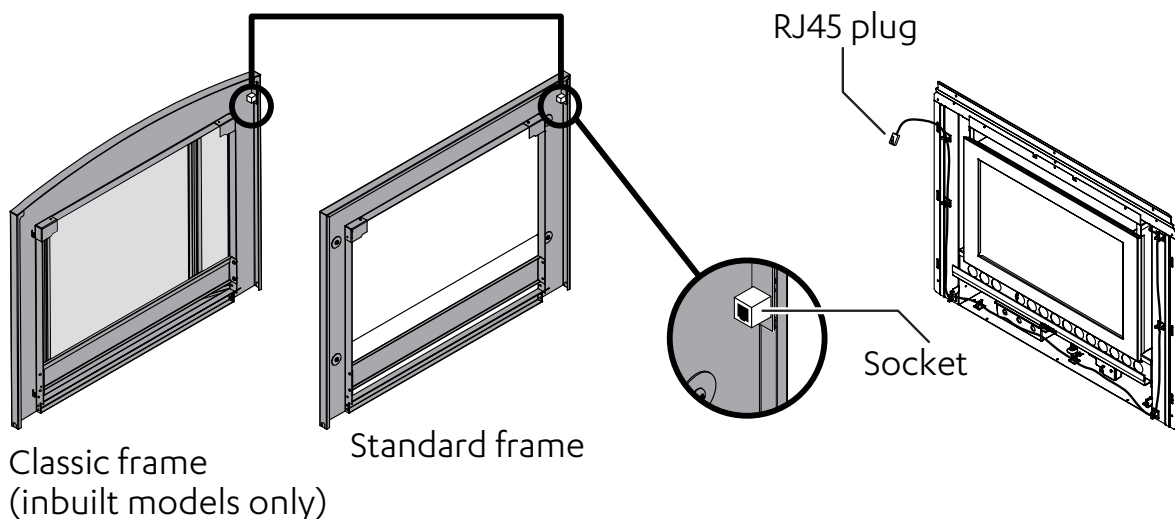

Commissioning

The gas pressures of the appliance are factory pre-set.



When commissioning the appliance electrical power will need to be connected. Exercise caution as there is potential for electric shock from exposed wiring and circuitry. DO NOT leave the appliance unattended when the power is connected and the panels are removed.

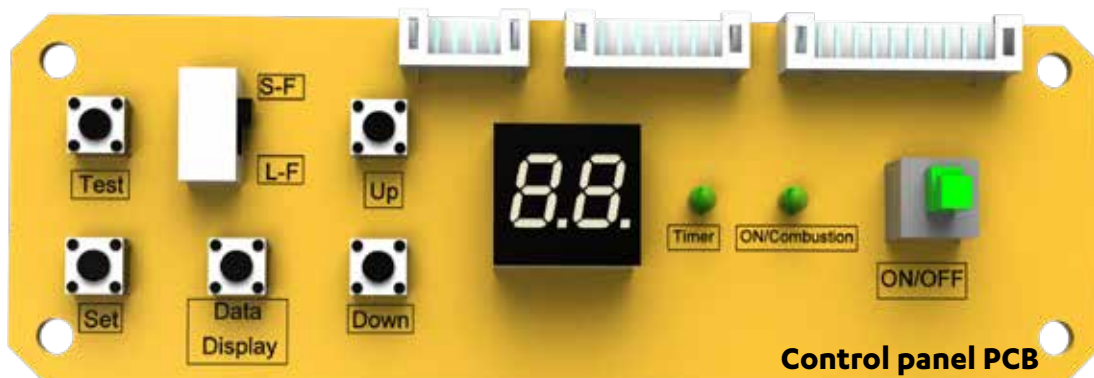

Check for the correct settings

The appliance display settings are shown on the LED display of the control PCB. If any of the settings are incorrect, check the appliance data plate (front left hand side).

Steps required to commission the PCB

Only required if the PCB is being replaced or after a gas type conversion—this needs to be done BEFORE the gas pressures are tested.

1. Turn on the gas supply.
2. With the appliance OFF, press 'Test', the gas type code will display. Press the 'Up' and 'Down' buttons to obtain the gas code for the unit, and press 'Set' to lock in the code.

A1 = NG L1 = LPG

The gas pressures can now be checked if required.

Gas pressure setting

Always check the pressures against those printed on the data plate of the appliance. If no adjustment is required during some stages of the process you will still need to push 'Set' to go to the next setting.

Checking the supply pressure

1. Remove the inlet test point screw and connect the manometer hose.
2. Press the heater ON/OFF button to start the ignition sequence, ensuring the correct flowing pressure is available with all other gas appliances operating on high.
3. Press the heater ON/OFF button to stop the heater operation.
4. Disconnect the manometer hose and replace the inlet test point screw.

Checking the pilot pressure

1. Remove the pilot test point screw and connect the manometer hose.
2. Press the heater ON/OFF button to start the heater.
3. Press the 'Test' button twice, the heater will light to the main burner on its lowest setting (stage 1) and the display will show PL.
4. Adjust the pilot pressure as required by manually adjusting the pilot regulator. Press the ON/OFF button to stop the heater operation.
5. Disconnect the manometer hose and replace the pilot test point screw.

Setting the operating pressure

1. Remove the gas control test point screw and connect the positive manometer hose.
2. Press the heater ON/OFF button to start the heater.
3. Press the 'Test' button twice, the heater will light to the main burner on its lowest setting (stage 1) and the display will show PL.
4. Press the 'Up' and 'Down' buttons to set the pressure for the appropriate gas type in accordance with the data plate. Press the 'Set' button once to save the setting.
5. The display will show PH (main burner stage 7). Press the 'Up' and 'Down' buttons to set the pressure for the appropriate gas type in accordance with the data plate. Press the set button once to save the setting.
6. The display will show 7. If the display does not change to 7 then there is an error in the commissioning and it should be carried out again.
7. Press the ON/OFF button to stop the heater.
8. Commissioning is now complete. Remove the manometer hose and replace the gas control test point screw.

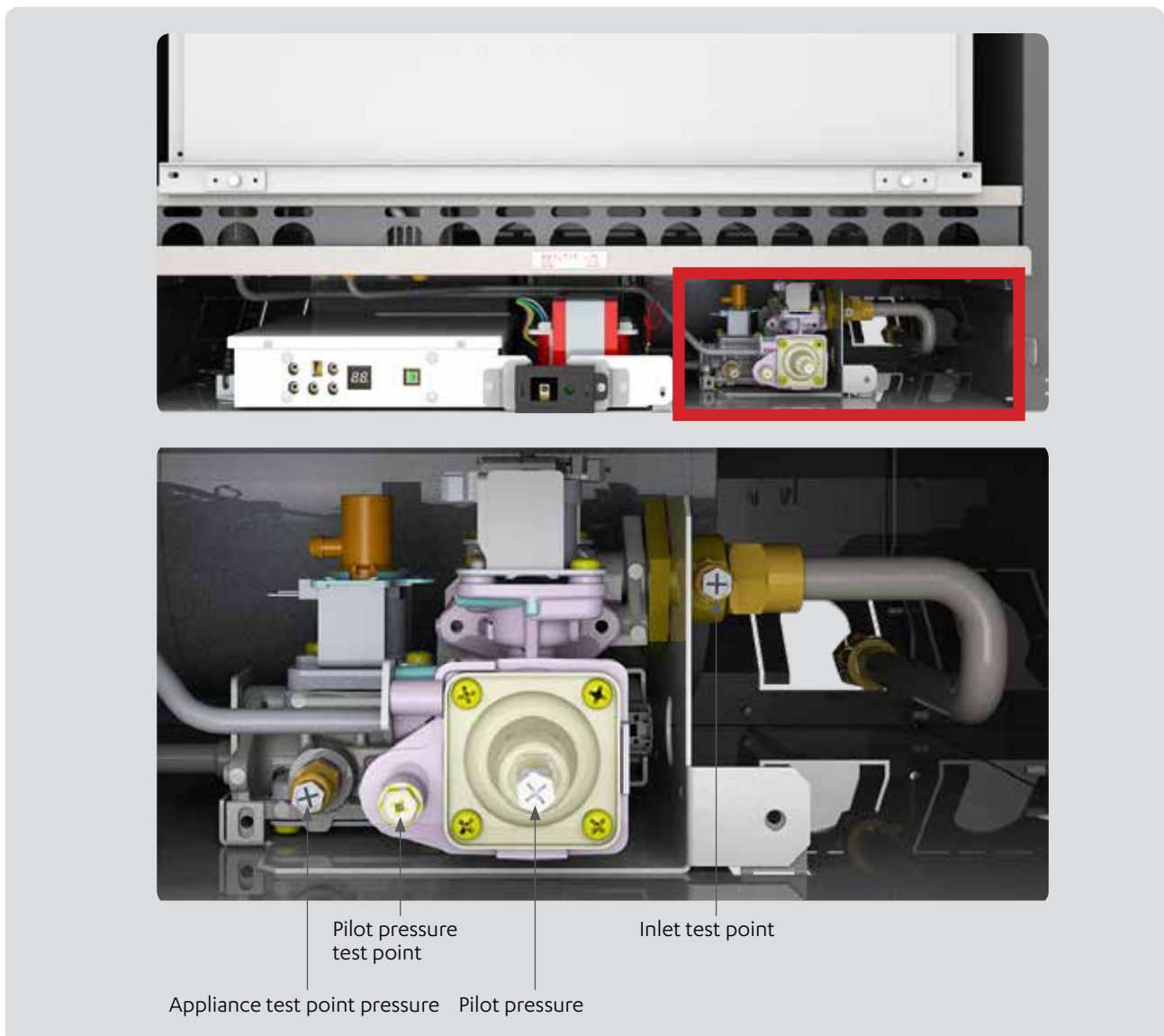

Outer frame and dress guard

Locate and remove the two frame assembly securing screws pre-positioned in the mounting tabs in the heater engine body. These screws have been pre-inserted to ensure correct threading of the frame securing tabs.

Attach the frame

Carefully pick up the outer frame assembly. Position the top fold over the frame assembly mounting panel and gently push the lower edge of the frame assembly until it is flush at the edges. Ensure you do not place excessive tension on, or pinch the communication cable when moving the frame into position.

Fit and tighten the two frame retaining screws through the frame and frame mounting tabs on the heater engine body.

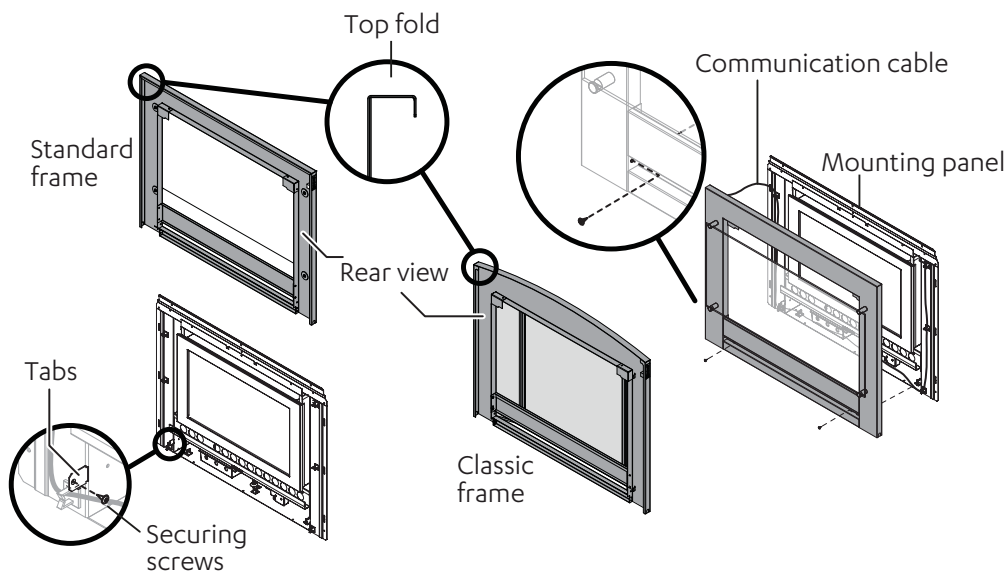

Classic frame: Attach the mesh dress guard

The mesh dress guard of the classic frame (inbuilt models only) is held in place by four slotted tabs (two on each side) which lock into four slots on the front of the frame.

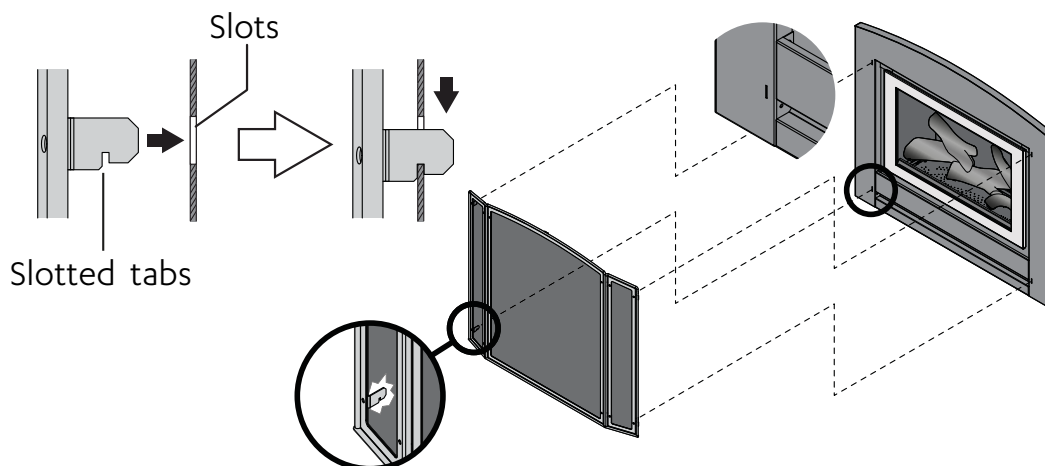

Flame pattern

It may take approximately two hours of operation for the logs to achieve their full flame pattern and glow. During the initial burning in period, some smoke and smell may be experienced. The appliance should run on the high setting in a well ventilated room until these dissipate. It is important to check the flame pattern during this time.

Abnormal flame pattern

Abnormal flame performance and/or pattern can indicate a problem with the fire, such as blocked gas injectors, or that the log set (burn media) has shifted. There are some warning signs that could indicate a problem.

- Unusual smell from the appliance
- Continued difficulty or delay in establishing a flame
- Flame appears either very short or very long
- Flame only burns part way across the burner
- Severe soot building up on the inside of the glass

Important

It is the responsibility of the installer to check that under normal conditions of the appliance, all flue gases are exhausted to the outside atmosphere, and that there is no spillage of combustion gases into the room.

If the appliance cannot be made to perform correctly please contact Rinnai.

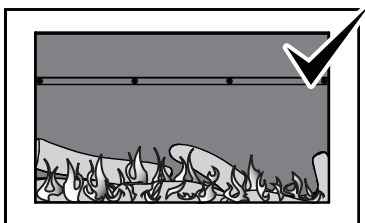

Normal flame pattern

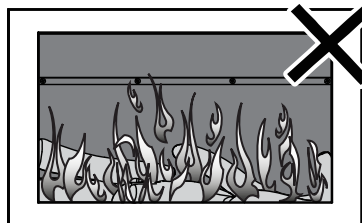

Abnormal flame pattern

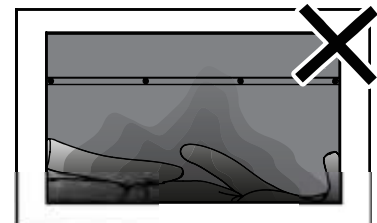

Soot build up

Customer handover

Complete the installation and commissioning checklist in the customer operation guide, and make sure you leave the guide with the customer. Explain to the customer about the use and care of the unit, and that they understand the instructions and operation of the appliance.

Wiring diagram

Mark	Part
B	Burner
ER	Electrode
F	Fuse Electrical
FM	Convection Fan Motor
FR1-2	Flame Rod 1-2
L	Light
OH.TH1	Over Heat Thermistor
PB	Pilot Burner
POV	Modulated Solenoid Valve
R.TH	Room Thermistor
RCR	Remote Control Circuit
SP	Sparker
SV1-3	Main Solenoid Valve 1-3
TF	Thermal Fuse
TR	Transformer

Mark	Colour
bk	black
bl	blue
gr/y	yellow-Green stripe
gy	grey
or	orange
pl	purple
r	red
w	white
y	yellow
p	pink
br	brown

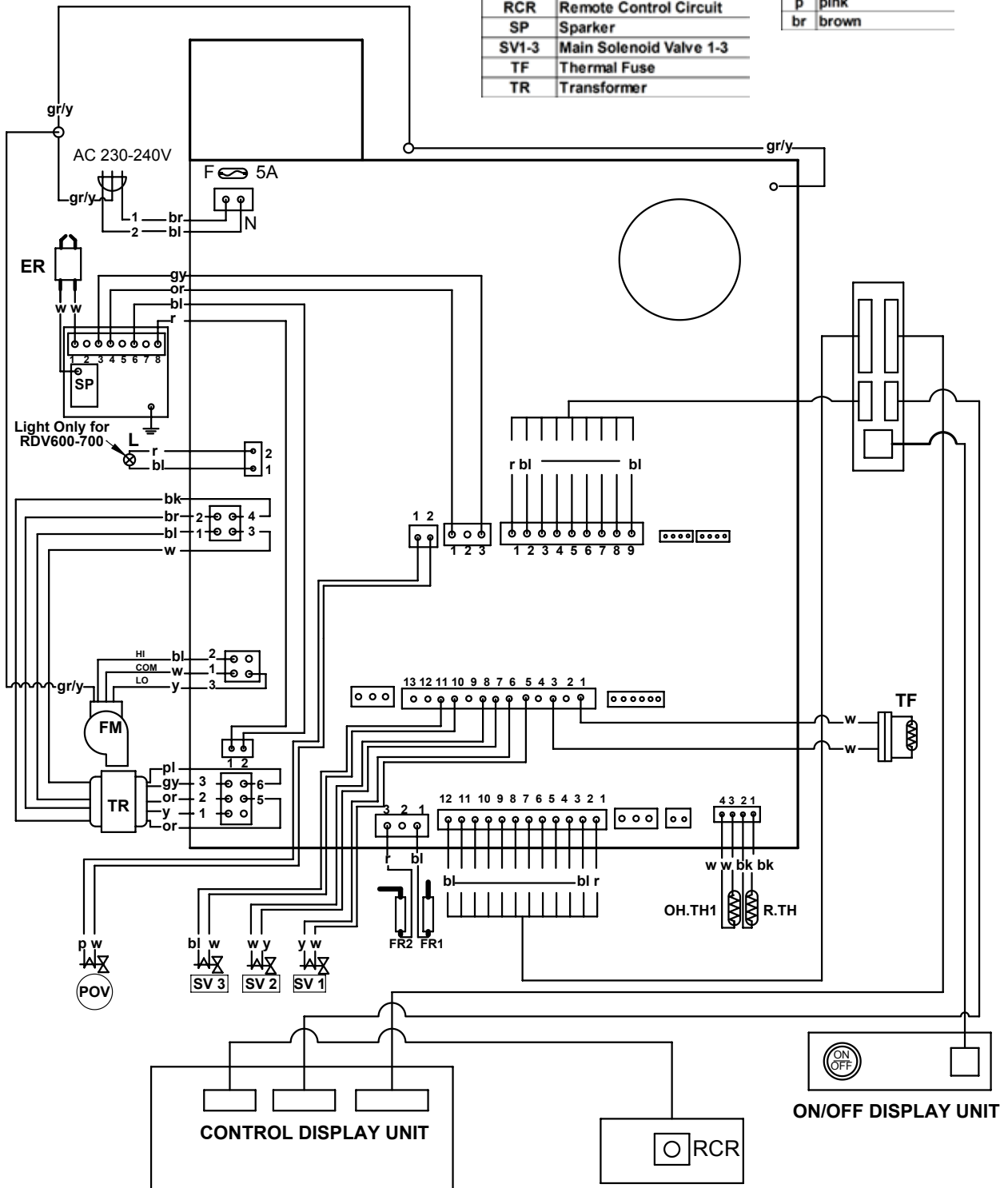

WIRING DIAGRAM UNI CONTROL MODEL 3
1 Burner
Issue B

Neo flueing

Every gas fire requires a flue system that will draw effectively and clear flue products safely under all potential wind and climatic conditions. It is the responsibility of the installer to ensure the appliance is provided with an effective flue.

Some guidelines to assist with flue design are detailed below. These must be read and modified as necessary depending on the installation. The Neo must be installed with an approved Rinnai flue system.

General flueing guidelines

Inner flue: Clearance to combustibles

Clearance from the inner flue to a combustible material must be greater than 25 mm.

Flue cowl clearance

To ensure products of combustion are cleared, adequate clearance for the building is required.

The flue cowl should have a 500 mm clearance from any part of the building. This also applies to steeped and pitched roofs where the flue cowl should be 500 mm clear of the ridge line. Adequate fresh air flow must exist around the flue cowl following installation.

Minimum clearances are shown in AS/NZS 5601.1.

Flue terminal locations

Must be compliant with 'Clearances Required for Flue Terminals' from AS/NZS 5601.1. The flue is not to terminate under floors or in a roof space.

Self-supporting flue

The weight of the flue system should not be supported by the appliance—it should be self-supporting. Supporting the flue is usually completed during the framing stage with flue supports or straps within the cavity.

Shared flues

Gas appliances must not be connected to a chimney or flue serving a separate fuel burning appliance.

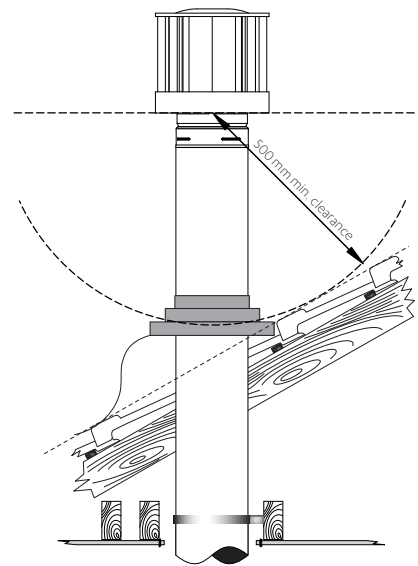

Flueing options

The below options detail the most common types of flue installations. If you have an installation that varies from those below, please contact Rinnai.

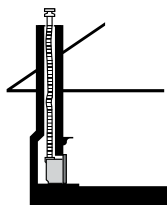

Masonry with flexiliner flue

For installations into a masonry cavity. Minimum flue length is 3.6m.

Flue components

- Flexiliner flue kit (R1756) 3.6 m

If flueing exceeds 3.6 m add:
- Flexiliner flue extension (R1761)

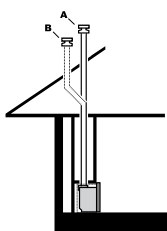

Inbuilt mock chimney direct and offset

For installations into a combustible opening with a zero clearance box, where the flue runs vertically in-wall.

A: Flue component

- Zero clearance flue kit (R1762Z)

B: Flue components

- Zero clearance flue kit (R1762Z)
- 45° bend kit x 2 (R1764)

If flueing exceeds 3.6 m add the galvanised or stainless steel flue extension (R1763Z, R1763SS).

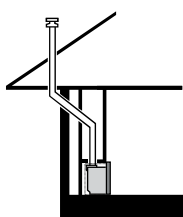

Inbuilt mock chimney offset wall penetration

For installations into a combustible opening with a zero clearance box. Flue runs in-wall, then penetrates the building before terminating vertically.

Flue components

- Zero clearance flue kit (R1762Z)
- Wall penetration kit (R1766)

If flueing exceeds 3.6 m add the galvanised or stainless steel flue extension (R1763Z, R1763SS).

Typically used in multi-storey dwellings where the fire is installed on the ground floor.

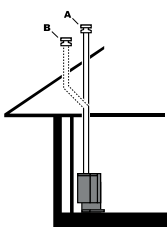

Freestanding vertical

Straight vertical or with an offset in the roof space.

Flue components

- FS galaxy black flue kit (R1762GL)
- FS brushed SS flue kit (R1762BS)

To offset the flue in the roof use 45° bends (R1764 x 2)

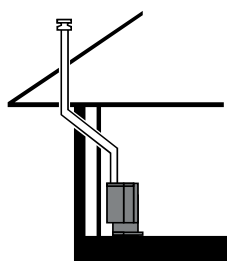

Freestanding with offset wall penetration

Flue runs vertically, penetrates the building before terminating vertically.

Flue components galaxy black

- FS galaxy black flue kit (R1762GL)
- Wall penetration kit blk. (R1766GL)

Flue components brushed SS

- FS brushed SS flue kit (R1762BS)
- Wall penetration kit galv. (R1766)

Typically used in multi-storey dwellings where the fire is installed on the ground floor.

Minimum flue length - 3.6 m: The minimum flue length is 3.6 m or three lengths of flue. This is required to ensure adequate draw and to prevent spill-back of combustion products, which can cause the safety sensors to shut down the fire. The minimum flue length before any bend or offset is 1.2 m (or one length of flue).

Maximum flue length - 8 m: Rinnai recommend a maximum flue length of 8 m with a maximum of two 45° bends.

Difference in flue lengths

For our inbuilt range flue lengths are 1.2 m. For the freestanding flues, those that are powder coated galaxy black and brushed stainless steel, flue lengths are 1. An easy way to remember is unpainted 1.2 m and painted 1 m.

Masonry flue installation with flexiliner flue

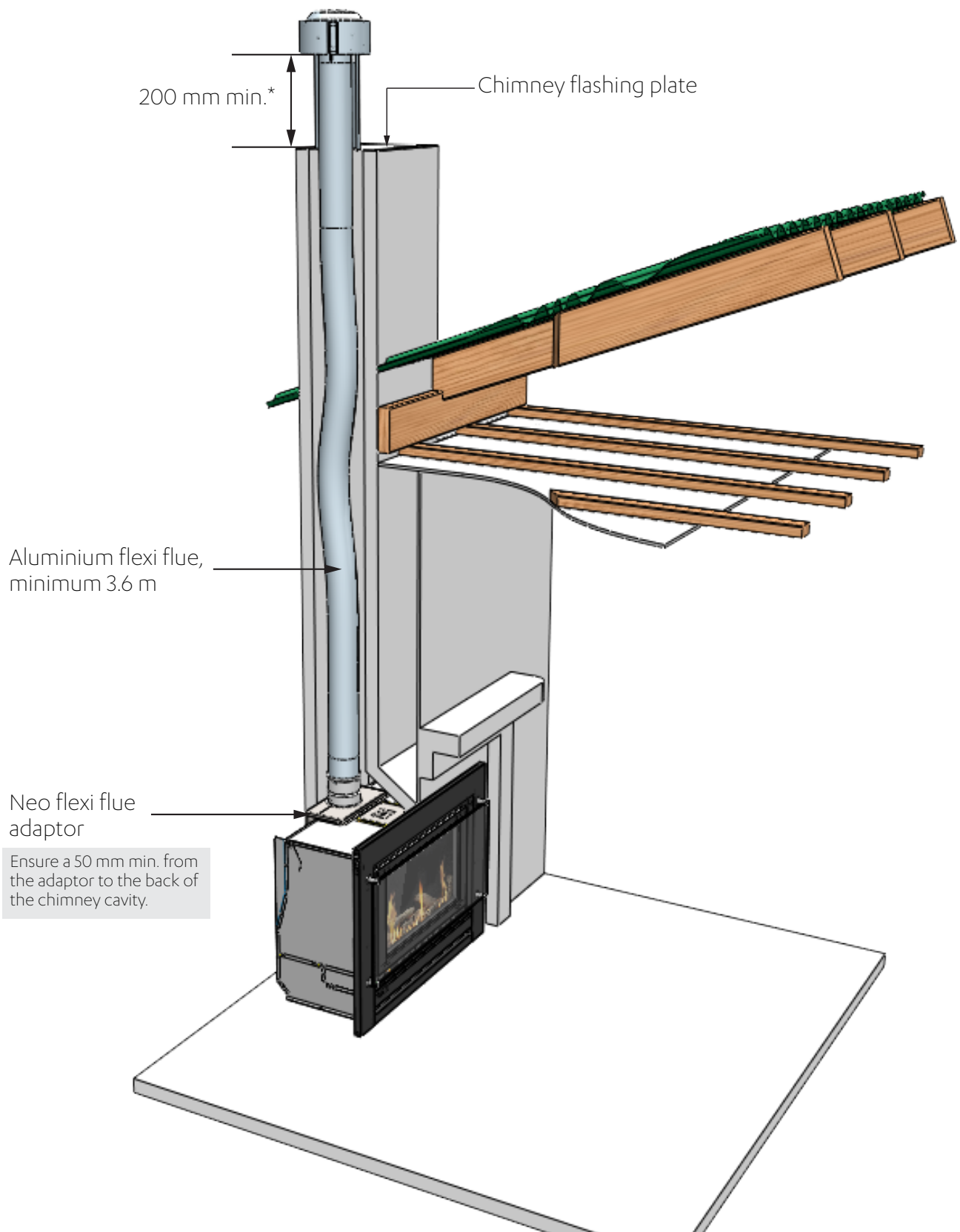

* The end of the flue shall be at least 200 mm from the nearest part of the chimney (AS/NZS 5601.1 6.9.2 (c))

Freestanding direct and offset flueing

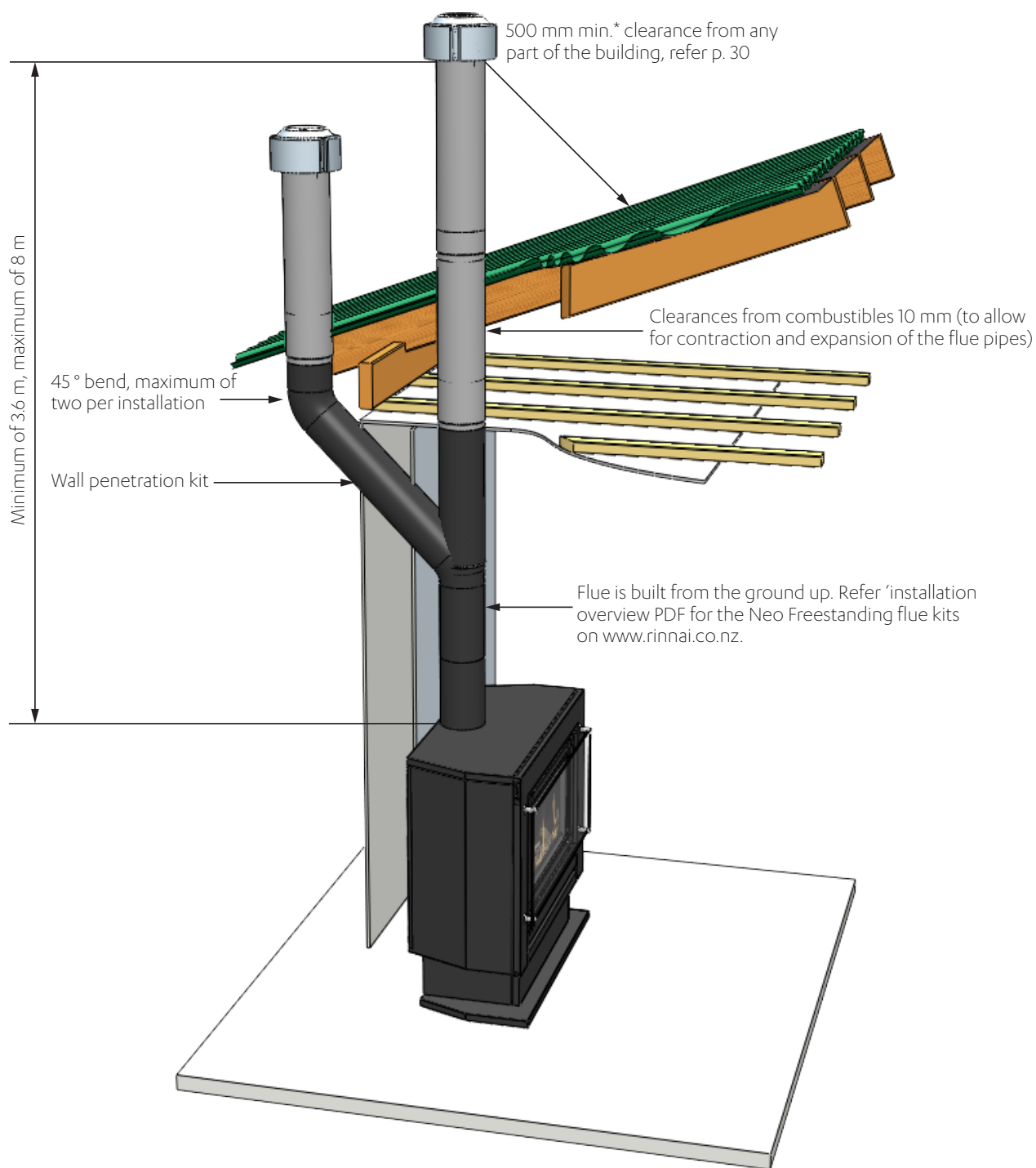

* The end of the flue shall be at least 500 mm from the nearest part of the chimney (AS/NZS 5601.1 6.9.2 (a))

*a touch.
of magic*



Experience our innovation

Rinnai.co.nz | **0800 746 624**

<http://www.youtube.com/rinnainz>

Neo RIB2312 Installation Guide: 12148-A 01-18