

The Rinnai logo is displayed in white, bold, sans-serif font on a solid red rectangular background.

# Installation guide

---

# Compact 2

Models: RIBF2N/RIBF2L



Standard frame



Traditional frame

**Installer, please note:**

The gas and electrical plate of the unit is not required when attaching the traditional frame, refer p. 18 for further information.

## Important:

For installations into a combustible opening, a Rinnai zero clearance box and flue kit are mandatory. Appliance must be installed with a Rinnai approved flue system.

This appliance shall be installed in accordance with:

- Manufacturer's installation instructions
- AS/NZS 5601.1 Gas Installations
- Local regulations and municipal building codes

Installation, servicing and repair shall be carried out only by authorised personnel.

### **WARNING**

Improper installation, adjustment, alteration, service or maintenance can cause property damage, personal injury or loss of life.

---

For more information about buying, using, and servicing of Rinnai appliances call: 0800 RINNAI (0800 746 624).

Rinnai New Zealand Limited  
105 Pavilion Drive, Mangere, Auckland  
PO Box 53177, Auckland Airport, Auckland 2150

Phone: (09) 257 3800, Fax: (09) 257 3899

Email: [info@rinnai.co.nz](mailto:info@rinnai.co.nz)

Web: [www.rinnai.co.nz](http://www.rinnai.co.nz)

[www.youtube.com/rinnainz](http://www.youtube.com/rinnainz)

[www.facebook.com/rinnainz](http://www.facebook.com/rinnainz)



# contents:

Specification.....	4
Enclosure dimensions .....	5
Clearances .....	6
Gas connection .....	8
Electrical connection .....	9
Flueing options.....	10
Flueing guidelines .....	11
Masonry flue installations.....	12
Masonry installation .....	14
Inbuilt mock chimney.....	16
Completing the heater installation .....	18
Flame pattern .....	20
Wiring diagram.....	21
<u>Appendix 1</u>	
Zero clearance installation overview.....	22

# Specification

All dimensions are in mm.

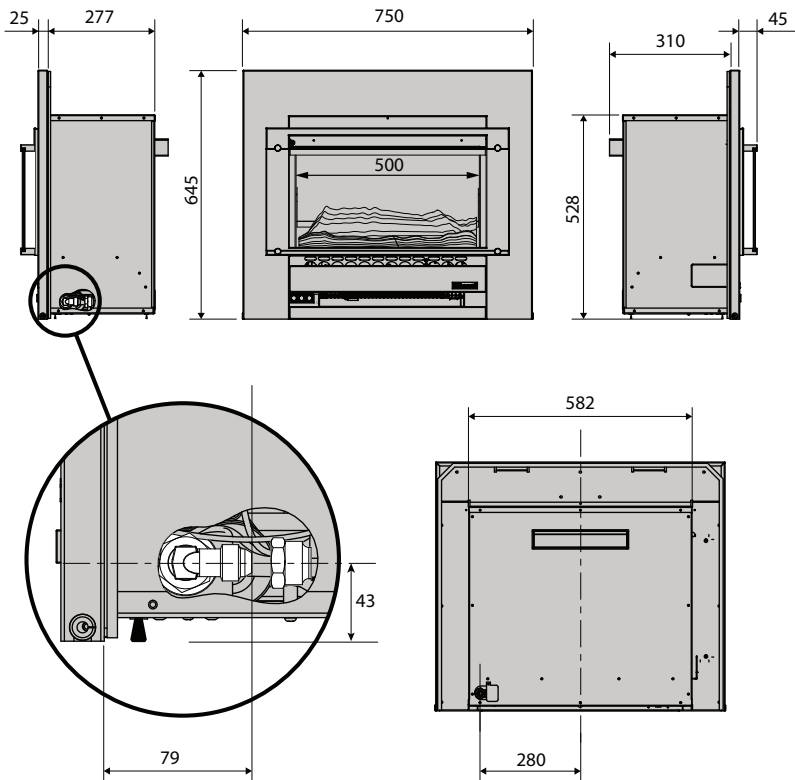

## Specification summary

Input	= 9-25 MJ/h
Output	= 1.6-5 kW*
Efficiency	= 73%
Energy star	= 2.8 stars*
Heating area	= 50-77 m <sup>2</sup> **
Gas type	= NG or ULPG

\* Will vary according to gas type and flue configuration

\*\* Will vary depending on geographical location in NZ

## Suitability

Suitable for masonry installations and installations into a mock (false) chimney. Ideally suited to living rooms and open plan areas.

## Installation considerations

The Compact 2 draws air for combustion from the room. Adequate ventilation must be calculated and provided by the gasfitter as per AS/NZS 5601.1.

## Burn media

Ceramic log set comes as standard.

## Convection fan

Convection fan tangential 2-speed. Heat is distributed from the top of the appliance.

## Data plate

Inside appliance on the front right hand side panel.

## Gas connection

½ " BSPF male flare, enters from the rear of the appliance.

## Ignition

Continuous spark electronic ignition.

**Noise level:** 49 dB(A)

## Operation

Push button to light pilot and burners.

## Flue - masonry

Rinnai recommends the use of a Rinnai flexiliner flue (flexi Ø 100 mm).

## Flue - mock chimney

Natural draft flue. Inner 100 mm, outer 150 mm. Appliance must be installed with a Rinnai flue system.

## Power consumption and electrical supply

High	= 20 W
Standby	= 0 W

Comes with a 1.5 m power cord and 3-pin plug. The electrical connection can exit the appliance from the lower left or right hand side, or from the rear of the heater.

## Safety devices

Flame failure thermocouple, overheat switch (bi-metal strip), fan delay, and power failure protection.

**Weight:** 39 kg

# Enclosure dimensions

The main points governing location are flueing and warm air distribution. The enclosure dimensions provided are critical to the installation of this appliance and must be adhered to.

The heater must be positioned on a flat level surface that allows free movement of the appliance.

## Inbuilt masonry installations

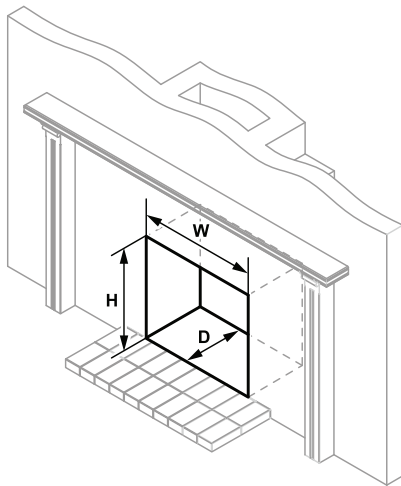

Inbuilt masonry	
<b>W-width</b>	595-700 mm
<b>H-height</b>	550-630 mm
<b>D-depth</b>	360 mm*

Use a slurry of sand and cement to level the base as required.

\* Minimum clearance required from the spigot to the back of the fireplace is 50 mm (p. 12).

## Inbuilt mock chimney installations

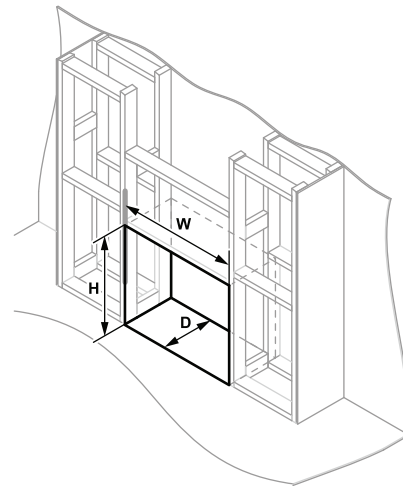

Inbuilt mock chimney	
<b>W-width</b>	685 mm
<b>H-height</b>	615 mm
<b>D-depth</b>	380 mm

The zero clearance box needs to be supported within the enclosure. Either construct a base using board with supporting joists or support with the frame itself—must be capable of supporting a minimum of 1.5 times the weight of the appliance.

When preparing a cavity/frame for a zero clearance installation, the total cavity depth MUST include the thickness of the external cladding as the zero clearance box MUST BE installed flush with the cladding surface, to ensure alignment of the flue.

# Clearances

The clearances listed below, measured from the **edge of the inner glass**, are minimum clearances unless otherwise stated.

## While the heater is operating

The appliance must not be installed where curtains or other combustible materials could come into contact with the heater. The 1000 mm clearance above is the clearance to the ceiling. The 300 mm side clearance includes side walls.

## Wall surface above the heater

The temperature of the wall surface directly above the appliance may get warm and discolour paint finishes or distort vinyl wall coverings. For durability of surfaces, please contact the manufacturer for their specification.

## Floor protection

Heat emanating from this fire may over time affect the appearance of some materials used for flooring, such as, carpet, vinyl, cork or timber. This may be amplified if the air contains cooking vapours or cigarette smoke. To avoid this occurring, it is recommended that a mat be placed in front of this appliance.

## Mantels and surrounds

Combustible mantels and surrounds require clearance from the unit to minimise the risk of fire. Mantels and surrounds, made of combustible materials such as wood, are allowed providing they are outside the minimum clearances shown.

## Hearths

A hearth is not necessary but can be used for decorative purposes or protection of sensitive flooring if required. A hearth must not obscure the front of the fire.

## TV installation above the fireplace

Installing a TV directly above the Compact 2 is **not recommended** due to the heat being emitted directly above the fire and also heat being generated from the flue components.

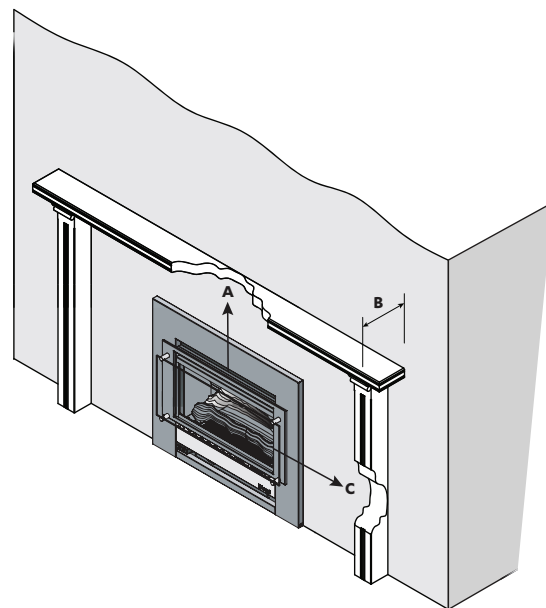
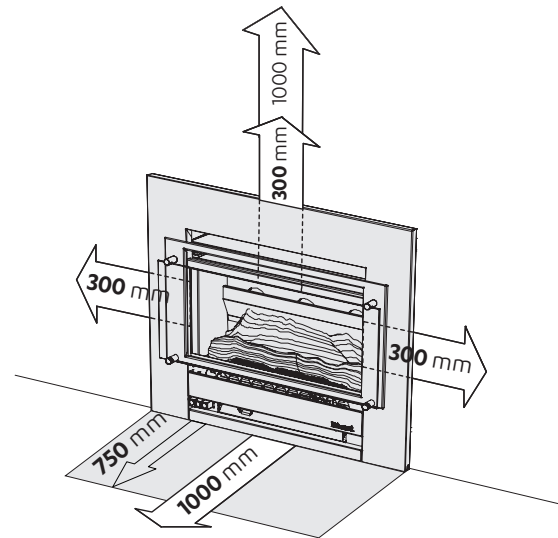

**A** Mantel needs to be a min. of 300 mm away from the edge of the glass.

**B** Maximum mantel depth at 300 mm (A) is 150 mm.

**C** Surround needs to be a minimum of 300 mm away from the edge of the glass.

For every 50 mm of added mantel depth there must be an additional 100 mm of clearance from the edge of the glass.

For example:

MANTEL DEPTH	A: CLEARANCE REQUIRED
200 mm	400 mm
250 mm	500 mm
300 mm	600 mm

The below diagrams are to assist people who are determining the clearance area around the Compact 2 without having the unit on site.

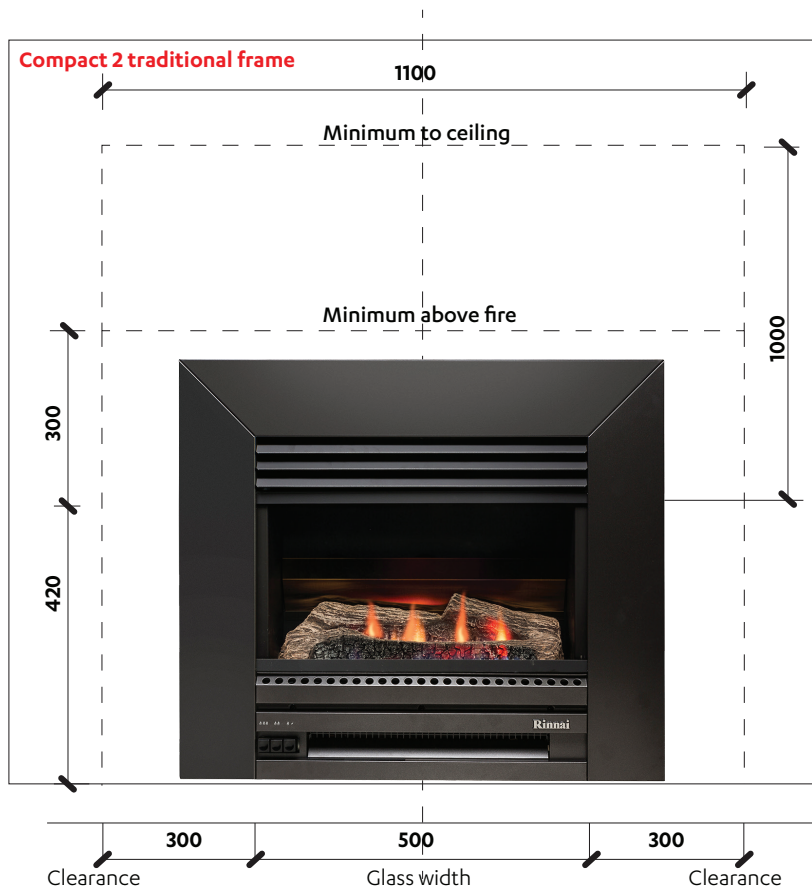
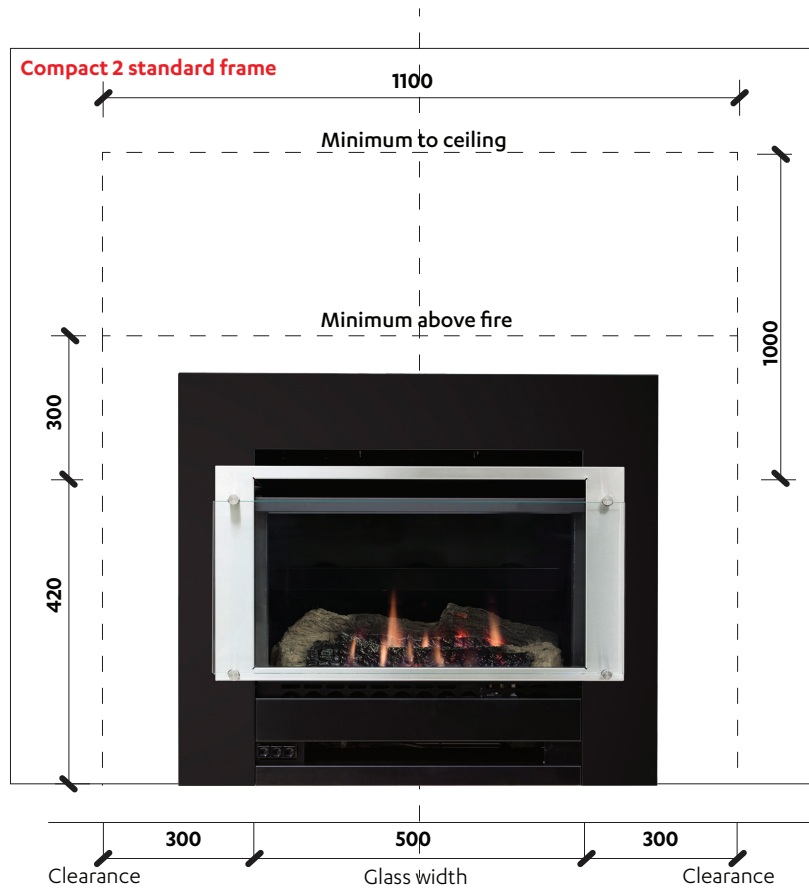



# Gas connection

Gas pipe sizing must consider the gas input to this appliance, as well as other gas appliances in the building. The gas supply termination is inside the heater, and enters from the rear of the appliance.

The length of the gas supply termination is measured from the front of the enclosure, including the thickness of any cladding material.

A ½ " BSP nut and a ½ " BSP male flare x ½ " barrel union - elbow are provided for connection to the gas supply. They are shipped inside the engine attached on the gas inlet connection of the heater.

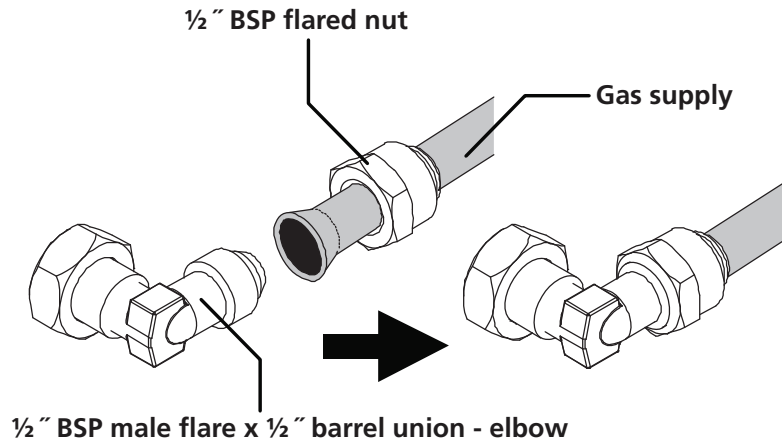

## Gas supply location

1. Mark off the location for the vertical centre line of the heater enclosure.
2. To the right of the vertical centre line, mark off both the vertical and horizontal location for the gas supply penetration.

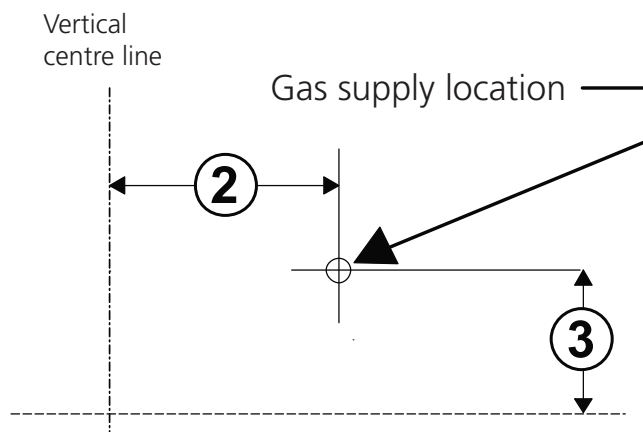

**2** = 280 mm to right of appliance centre line

**3** = 43 mm from base of enclosure

**4** = Gas supply to be terminated 79 mm from the front of the enclosure

## Purging gas supply

Foreign materials and debris such as swarf, filings etc must be purged from the gas supply. Failure to do so may cause damage to the control valve causing it to malfunction.

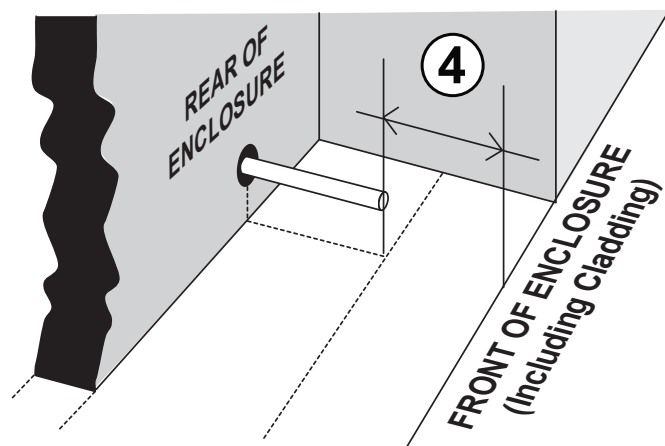



# Electrical connection

If a power point is used it must be 230 V, rated 10 A, and must be earthed. The power point **MUST NOT** be located above the heater. Alternatively the appliance can be direct wired if the power supply is to be concealed.

The Compact 2 is fitted with a 1.5 m power cord. The electrical connection can exit the appliance from the lower left or right hand side, or from the rear.

## Direct wired installations



A qualified electrician will need to be consulted where a direct wired installation is required.

Installation must comply with the requirements of AS/NZS 5601.1, AS/NZS 3000 and any other relevant local regulations.

## Using existing externally mounted power points on inbuilt installations

If there is an existing wall plug located outside of the intended fireplace or enclosure you can redirect the power cord and plug assembly through the front panel. With the frame assembly removed, redirect the cord and plug assembly (with grommet) underneath the heater to the front of the unit—either left or right hand side.

Carefully remove the pre-punched metal knock-out section on either the left or right hand side of the frame assembly. Refit the cord and plug assembly to the frame assembly ensuring the grommet is fitted to the sheet metal. Excess cord may be left in the cavity **BELOW** the unit. **DO NOT** coil the excess cord.

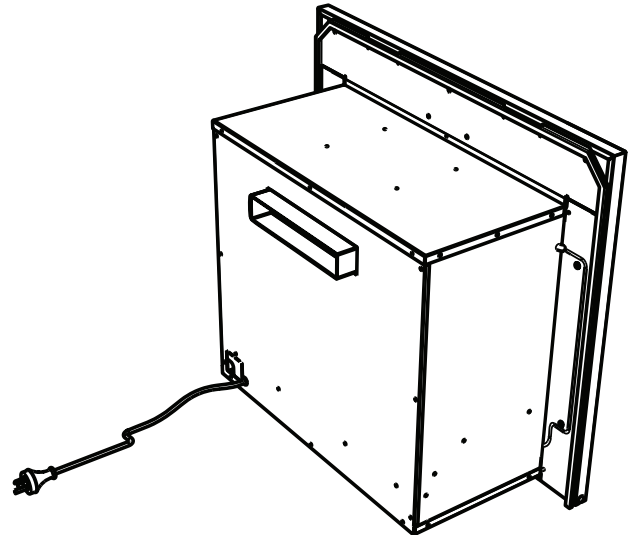

Compact 2 power cord position - exiting rear of the appliance

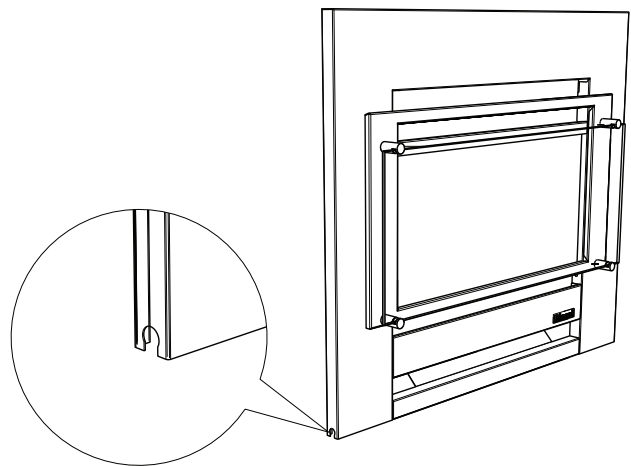

Compact 2 frame assembly - highlighting position of metal knock-out tab

# Flueing options

The below options detail the most common types of flue installations. If you have an installation that varies from those below, please contact Rinnai.

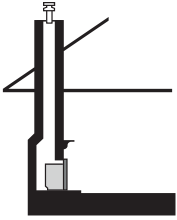

## Masonry without a flexiliner flue

For installations into a masonry cavity where the chimney has been swept, checked for soundness and ability to achieve a good draw.

## Flue component

- Flue cowl (R1760-2)

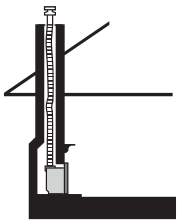

## Masonry with flexiliner flue

For installations into a masonry cavity where a Rinnai aluminium flue is required to ensure optimum performance of the appliance.

## Flue components

- Flexiliner flue kit (R1758) 3.6 m

If flueing exceeds 3.6 m add:  
- Flexiliner flue extension (R1761)

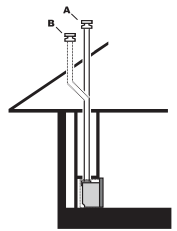

## Inbuilt mock chimney direct and offset

For installations into a combustibile opening with a zero clearance box, where the flue runs vertically in-wall.

## A: Flue component

- Zero clearance flue kit (R1762Z)

## B: Flue components

- Zero clearance flue kit (R1762Z)  
- 45° bend kit x 2 (R1764)

If flueing exceeds 3.6 m add the galvanised or stainless steel flue extension (R1763Z, R1763SS).

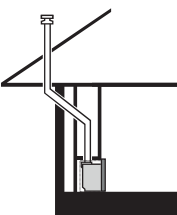

## Inbuilt mock chimney offset wall penetration

For installations into a combustibile opening with a zero clearance box. Flue runs in-wall, then penetrates the building before terminating vertically.

## Flue components

- Zero clearance flue kit (R1762Z)  
- Wall penetration kit (R1766)

If flueing exceeds 3.6 m add the galvanised or stainless steel flue extension (R1763Z, R1763SS).

## Masonry installations

Rinnai recommends the use of a flexiliner flue (Ø 100 mm) as it ensures optimum performance of the appliance. Installation without a flexiliner flue is permitted as long as the chimney has been swept, checked for soundness and ability to achieve a good draw.

## Mock chimney flueing

A Rinnai zero clearance box and flue kit are mandatory for installations into a combustibile opening.

## Minimum flue length - 3.6 m

This is required to ensure adequate draw and to prevent spill-back of combustion products, which can cause the safety sensors to shut down the fire. The minimum flue length before any bends or offsets is 1.2 m (or one length of flue). The minimum vertical flue length is 3.6 m or three lengths of flue.

## Maximum flue length - 8 m

Rinnai recommends a maximum flue length of 8m with a maximum of two 45° bends.

# Flueing guidelines

Flashings to the top of the chimney structure do not form part of the flue kit and must be specified.

## Inner flue: Clearance to combustibles

Clearance from the inner flue to a combustible material must be greater than 25 mm.

## Flue cowl clearance

To ensure products of combustion are cleared, adequate clearance for the building is required.

The flue cowl should have a 500 mm clearance from any part of the building. This also applies to steeped and pitched roofs which should be clear of the ridge line as shown. Lesser clearances may provide perfectly adequate flue systems depending on the installation. Minimum clearances are shown in AS/NZS 5601.1.

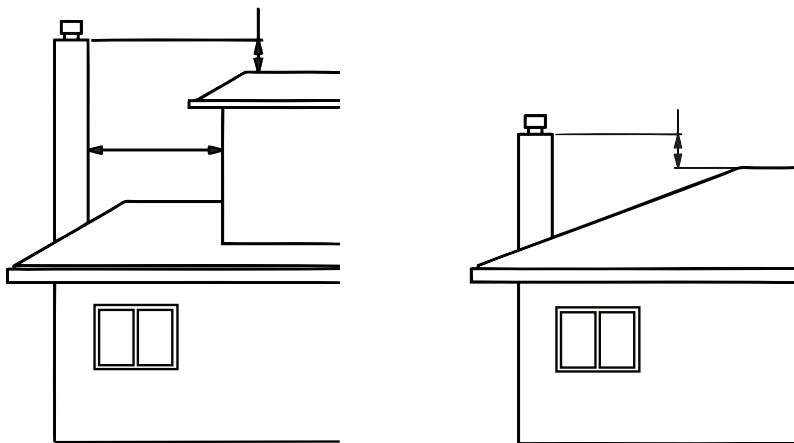

## Flue terminal locations

Must be compliant with 'Clearances Required for Flue Terminals' from AS/NZS 5601.1. The flue is not to terminate under floors or in a roof space.

## Self-supporting flue

The weight of the flue system should not be supported by the appliance—it should be self-supporting. Supporting the flue is usually completed during the framing stage with flue supports or straps within the cavity.

## Shared flues

Gas appliances must not be connected to a chimney or flue serving a separate fuel burning appliance.

# Masonry flue installations

There are two types of masonry flue installations; open chimney and lined chimney. An open chimney uses the natural draft properties of a sound chimney, an approved chimney plate and cowl to provide flueing for the heater. A lined chimney installation is used when the existing chimney condition is inadequate for an open chimney installation and uses a Rinnai flexiliner flue to provide flueing for the heater.

## Check dimensions of opening

Ensure opening is within the range provided (p. 5), and if necessary bring them to the required dimensions. Also check chimney height as inadequate height can affect product performance. Some installations may require the chimney height to be extended to reduce down drafts. Also check there are no obstructions.

Provide a solid, flat, and sealed base, otherwise noise and vibration may result. Sealed means no holes or openings in the fireplace.

## Some criteria for checking chimney soundness

Rinnai strongly recommends the use of a Rinnai flexiliner flue system. Failure to meet this criteria may result in an unsafe situation. Installation without a flexiliner flue is permissible as long as the chimney is swept, checked for soundness and ability to achieve a good draw. Some criteria for checking soundness:

- All loose/broken bricks must be replaced or repaired ensuring the chimney is of sound construction and does not leak.
- Chimney must be swept clean and be free from soot and creosote that may have built up if previously used for a solid fuel fire.
- Any damper plate must be fixed in an open position or removed.
- Any underfloor air supply to the fireplace must be completely sealed to prevent secondary air draw.

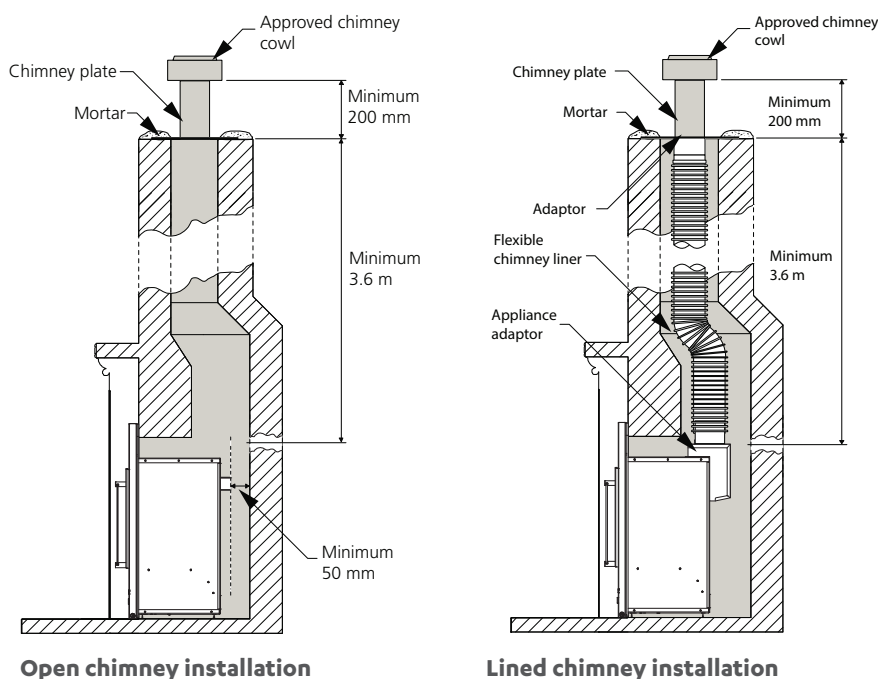



# Installation

Installation, servicing and repair shall be carried out only by authorised personnel.

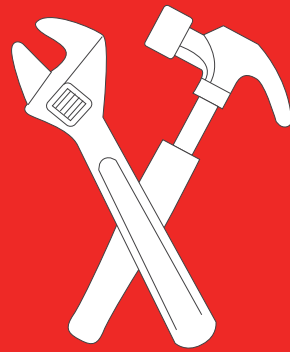

# Masonry installation

Adapt instructions as necessary for masonry installations without a flexiliner flue.

**1. Prepare site:** Ensure the enclosure meets the dimension requirements and check the gas and electrical supplies have been prepared according to the information in this guide.

**2. Unpack engine:** The Compact 2 engine is supplied in one carton. Check for damage and ensure you have the correct gas type before starting. Do not install if any damage is evident.

**3. Install flue:** Install flexiliner flue if applicable, refer next page for an overview of how the flue is assembled and connected to the unit.

**4. Prepare engine:** Attach the adhesive backed foam sealing strip (supplied) to the rear face of the front assembly mounting panel at approximately 20 mm from the top edge.

The foam strip forms a seal

between the heater and the fireplace brickwork. If an adequate seal cannot be formed then another means of sealing must be used (non-combustible insulation or heat resistance silicon).

Unscrew the five screws securing the gas/electrical plate and put aside.

**5. Connect flue adaptor:** Connect the flue adaptor to the flexiliner flue.

**6. Position engine:** Place the Compact 2 engine in front of the fireplace enclosure. Use a panel of the cardboard packaging underneath the engine to minimise damage to the floor.

**7. Connect electrical supply:** Plug in the 3-pin connector of electrical connection inside the fireplace.

**8. Insert unit into fireplace:** Carefully move the heater into the fireplace ensuring the gas supply pipe and fittings feed into the rear access hole. Connect the flue (refer next page).

**9. Connect gas supply:** Connect gas supply pipe and fittings to the gas control valve inlet and tighten.

**10. Leak test:** Leak test all appliance connections. When finished remove any residue with a rag. Prevent any soapy solution coming into contact with the electrical components.

**11. Secure:** Fasten the heater to the masonry using appropriate fasteners (not supplied). There are three holes across the top of the front assembly mounting and side panels.

**12. Complete installation:** Refer to instructions on p. 18.

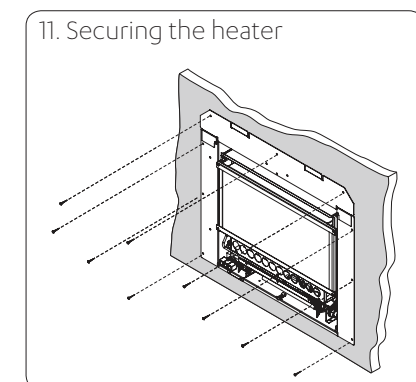
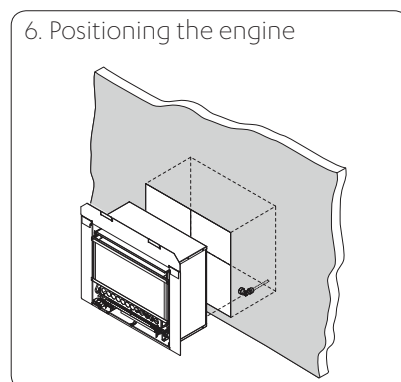
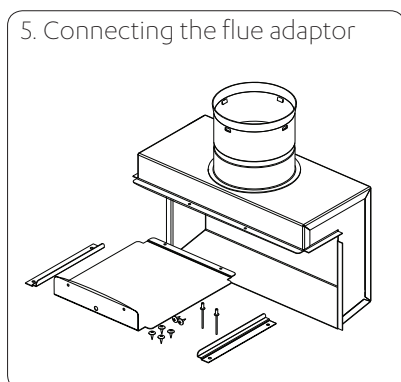
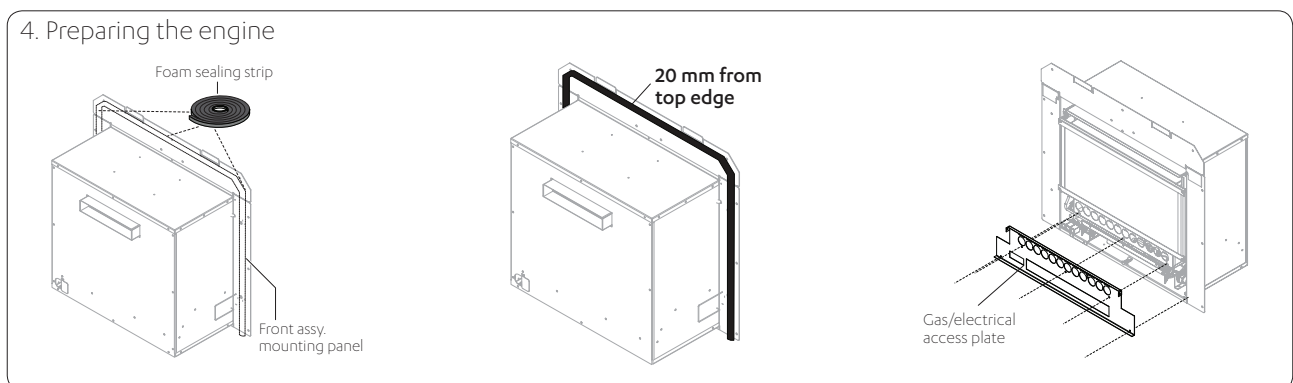

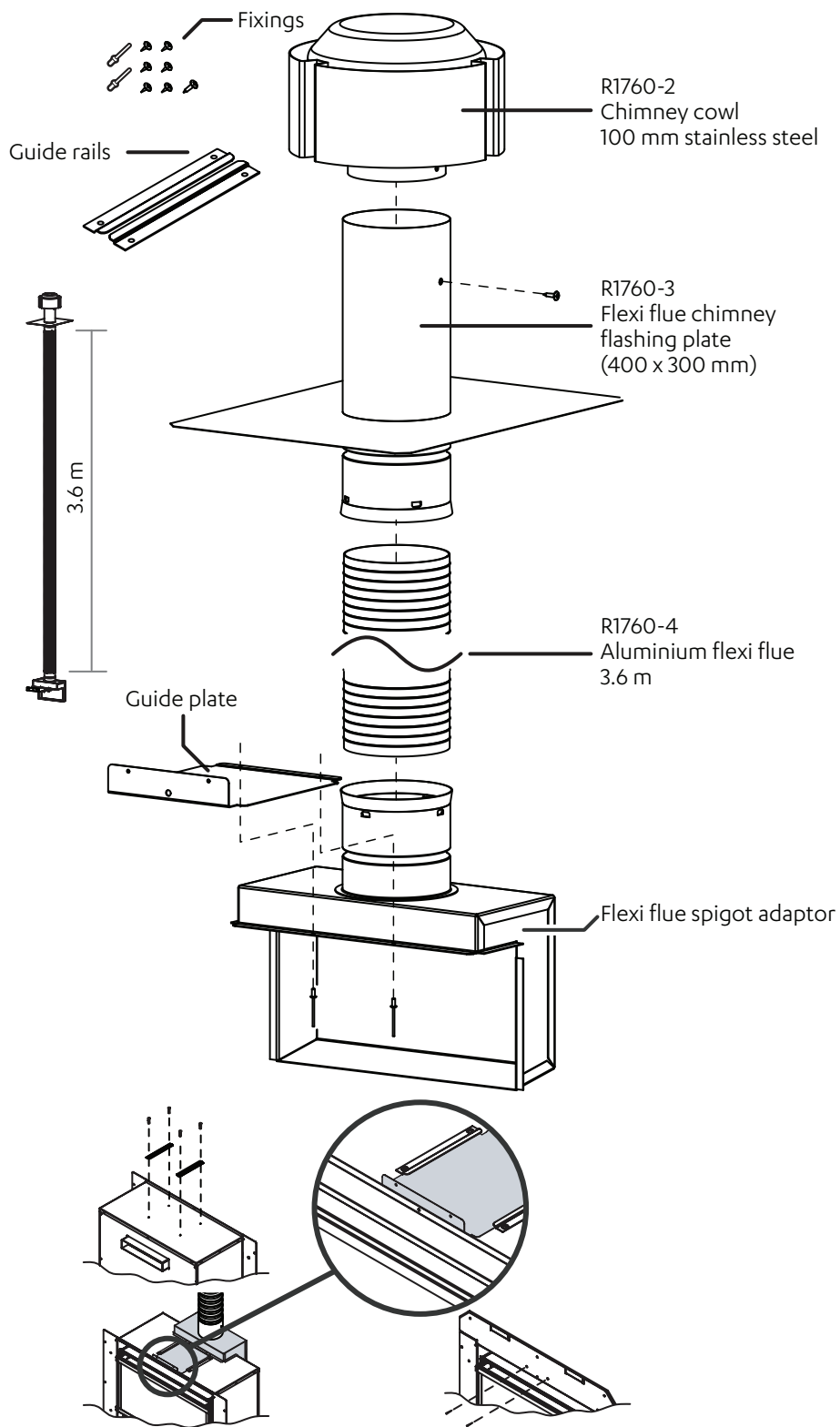

### Attaching the flexiliner flue to the unit

1. Attach the guide rails to the heater using the predrilled holes and four screws.
2. Align the guide plate with the guide rails and slide the flue assembly forward until the front tab of the guide plate is fully forward and against the rear of the flange at the top of the heater.
3. Ensure the guide plate is securely fastened with two screws to the flue access plate.

# Inbuilt mock chimney (zero clearance installation)

**1. Prepare site:** Ensure the enclosure meets the dimension requirements and check the gas and electrical supplies have been prepared according to the information in this guide.

Ensure there are no walls, studs, noggins, ceiling joints, wiring, or other obstructions within the wall or ceiling cavity where the flue is to be located.

**2. Assemble zero clearance box:** Refer separate assembly instructions included with the zero clearance box.

**3. Fit zero clearance box:** Slide assembled box into the cavity, ensuring the gas and electrical supplies are accessible.

**4. Install flue:** Install flue kit and/or components, refer p. 22 for an overview of how all the components fit together.

**5. Unpack engine:** The Compact 2 engine is supplied in one carton. Check for damage and ensure you have the correct gas type before starting. Do not install if any damage is evident.

**6. Prepare engine:** Attach the flue guide rails, supplied with the zero clearance box, to the top of the heater engine using the four predrilled holes and screws supplied.

Remove and put aside the flue access plate and gas/electrical plate.

**7. Fit cladding:** Before installing the heater ensure the cladding for the front of the enclosure has been fitted. The cladding MUST BE installed flush with the zero clearance box. Failure to do this will cause alignment problems with the flue.

**8. Connect flue adaptor:** Connect the flue adaptor\* to the engine by aligning the guide rails with the guide plate\* of the flue adaptor. Slide the flue adaptor in until the guide plate is fully home against the rear of the flange of the heater at the top of the heater.

\* Supplied with the zero clearance box

**9. Position engine:** Place the Compact 2 engine in front of the fireplace enclosure. Use a panel of the cardboard packaging underneath the engine to minimise damage to the floor.

**10. Connect electrical supply:** Plug in the 3-pin connector of electrical connection inside the fireplace.

**11. Insert unit into fireplace:** Carefully move the heater into the fireplace ensuring the gas supply pipe and fittings feed into the rear access hole.

**12. Connect flue:** The weight of the flue should not be supported by the appliance, it should be self-supporting. Supporting the flue is usually completed during the framing stage with flue supports or straps within the cavity.

**13. Secure flue:** Replace the flue access plate and secure the guide plate of the flue adaptor to the flue access plate with the two screws supplied.

Secure access plate to the heater.

**14. Connect gas supply:** Connect gas supply pipe and fittings to the gas control valve inlet and tighten.

**15. Secure heater:** Fasten the heater to the cladding using appropriate fasteners (not supplied). There are three holes across the top of the front assembly mounting panel, and side panels.

**16. Leak test:** Leak test all appliance connections. When finished remove any residue with a rag. Prevent any soapy solution coming into contact with the electrical components.

**12. Complete installation:** Refer to instructions on p. 18.



2. Assemble the zero clearance box

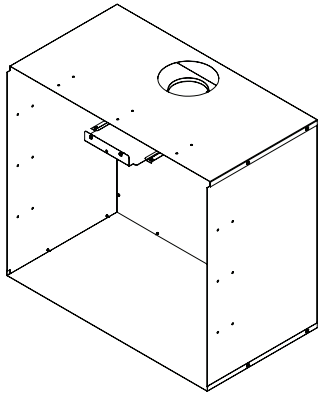

3. Fit zero clearance box

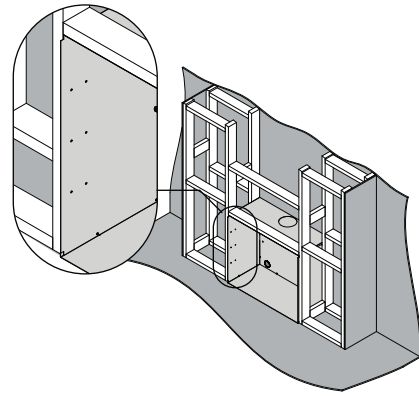

6. Prepare heater engine

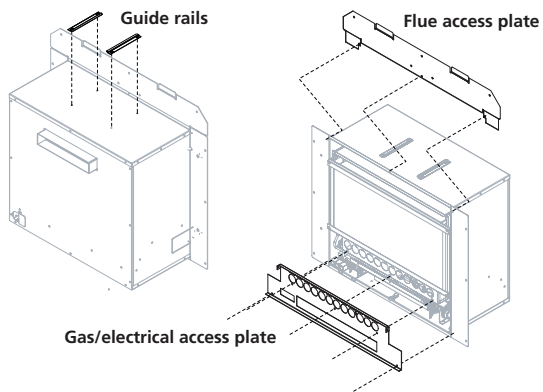

7. Fit cladding

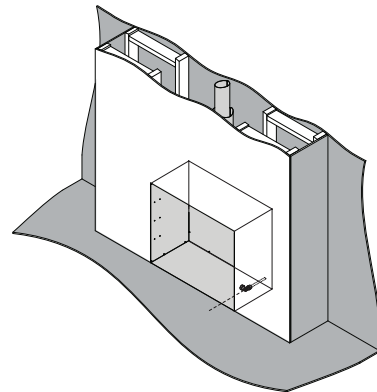

8. Connect flue adaptor

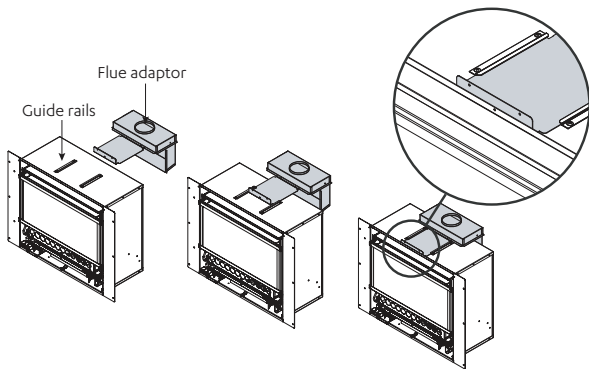

13. Secure flue

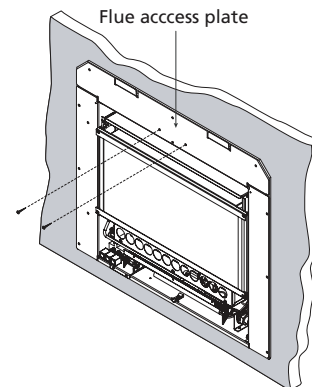

15. Secure the heater

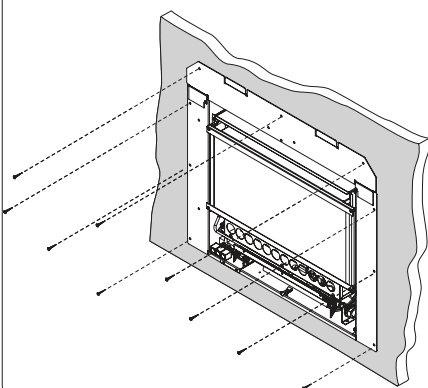

# Completing the heater installation

## 1. Remove combustion chamber glass

Loosen, but do not remove the bottom two retaining screws.

While supporting the combustion chamber glass panel, completely unscrew and remove the two remaining screws and clamp. Lift the combustion chamber glass panel and place aside.

## 2. Unpack log set and granules

Carefully unpack the log set and inspect for damage. If any damage is evident, do not continue with the installation.

The satchel containing the burner granules is taped to the outside of the foam packing that contains the log set.

## 3. Install log set and granules

Use extreme care when handling the log set as it is fragile and will damage easily.

To position correctly, hold the log set at approximately 45° directly in front of the combustion chamber. Maintain this angle and place the front feet of the log set behind the unpainted inner horizontal steel lip of the combustion chamber.

To set the log set into the final position, rotate the back of the log set down, using the location of the front feet as pivot points, until it is sitting flat on the rear burner.

Check the correct position of the log set before installing the granules. Ensure the log set is firmly seated in the centre of the combustion chamber and not touching the side walls, and that the ports are clear of any debris that may have occurred during installation.

Carefully place (do not pour) the granules over and around the front burner ports. It is beneficial that the gas jet is diffused by the granules. This will reduce any candling effect of the flame and enhance the realistic log-burning look of the heater.



Do not force, or block the burner ports with the granules and do not place any granules on the rear burner.

## 4. Replace combustion chamber glass and turn on electrical supply

## 6. Check burner pressures

Turn gas supply on, and refer to the data plate on the appliance for the correct gas pressure settings.

Remove the pressure test point screw and attach a manometer to the test point situated on the front of the injector block.

Light the heater, select the high heat setting, and check the pressure. If adjustments are necessary, the regulator is situated on the front of the gas control.

After checking pressures, turn the unit off, remove manometer, and replace test point screw.

Turn the heater on and off a few times to check ignition. When you are satisfied that the heater is working check the flame pattern, refer p. 20.

## 7. Attach frame assembly

Re-attach the gas/electrical plate. DO NOT do this if you are installing the traditional frame as this already has the plate included.

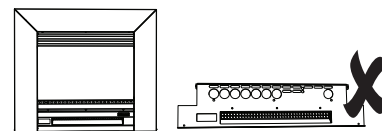

Traditional frame - gas/electrical plate not required

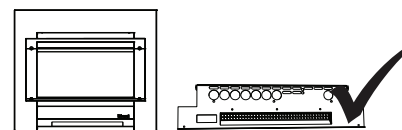

Standard frame - gas/electrical plate required

Carefully pick up the frame assembly\* and position the top fold over the mounting tabs and gently push the lower edge of the frame down over the unit.

Fit and tighten the frame to the unit using two screws for the standard frame or three screws for the traditional frame.

\* Standard frame: Do not tilt on its edge as the glass may slide out off the standoff posts.

## 8. Complete the installation checklist

Complete the installation and commissioning checklist in the customer operation guide, and make sure you leave the guide with the customer.

Explain to the customer about the use and care of the heater, and ensure they understand the instructions and operation of the appliance.

1. Removing the combustion chamber glass panel

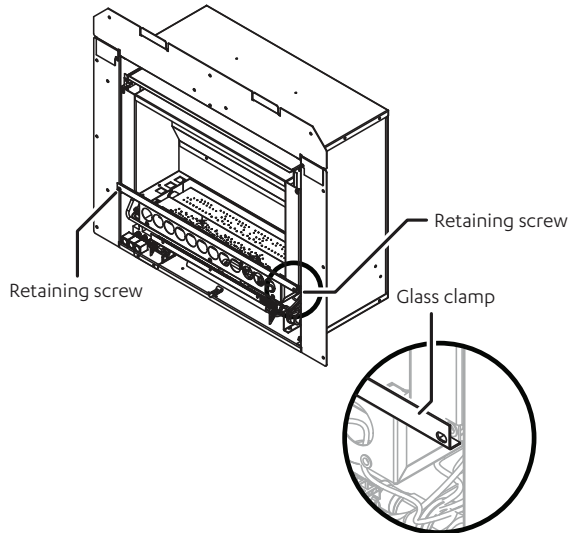

1. Install log set and granules

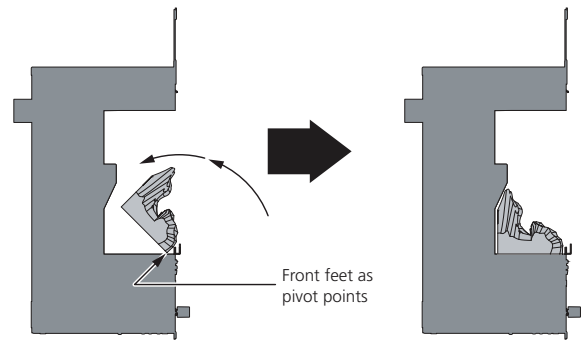

6. Check burner pressures

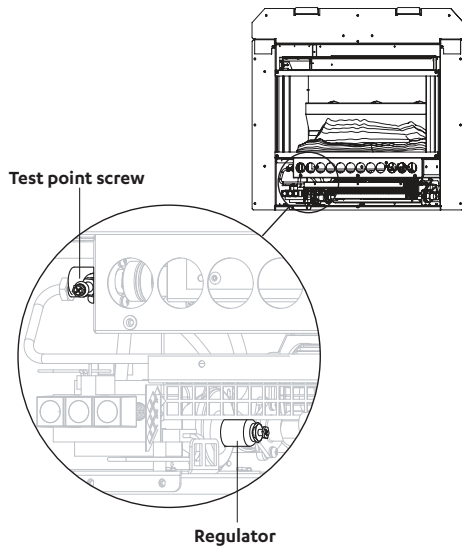

7. Attach frame assembly

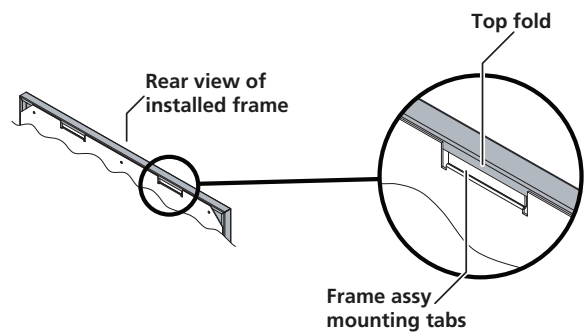

7. Attach frame assembly: Standard frame

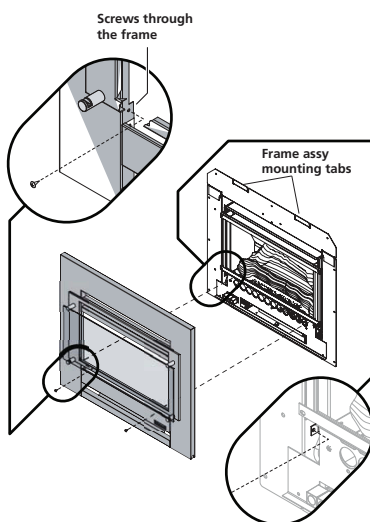

7. Attach frame assembly: Traditional frame

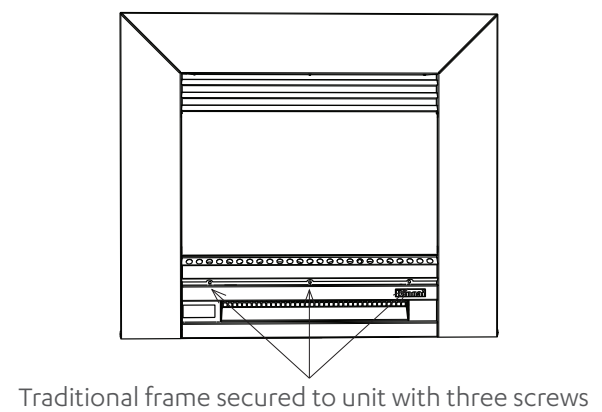

# Flame pattern

It may take approximately two hours of operation for the logs to achieve their full flame pattern and glow. During the initial burning in period, some smoke and smell may be experienced. The appliance should run on the high setting in a well ventilated room until these dissipate. It is important to check the flame pattern during this time.

## Abnormal flame pattern

Abnormal flame performance and/or pattern can indicate a problem with the fire, such as blocked gas injectors, or log set (burn media) has shifted from when the fire was first installed. There are some warning signs that could indicate a problem.

- Unusual smell from the appliance
- Continued difficulty or delay in establishing a flame
- Flame appears very short or very long
- Flame only burns part way across the burner
- Severe soot building up on the inside of the glass

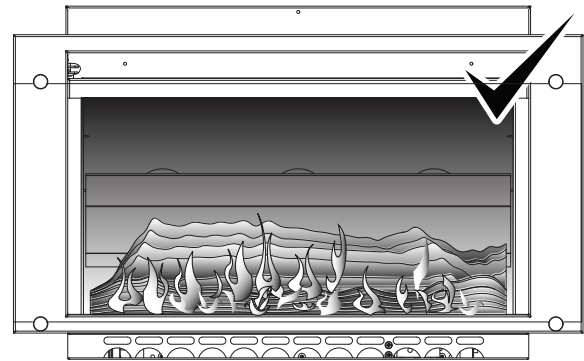

**Normal flame pattern**

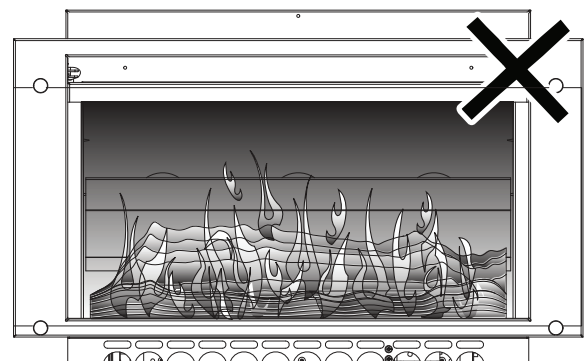

**Abnormal flame pattern**

## Important

It is the responsibility of the installer to check that under normal conditions of the appliance, all flue gases are exhausted to the outside atmosphere, and that there is no spillage of combustion gases into the room.

If the appliance cannot be made to perform correctly please contact Rinnai.



# Wiring diagram (10153)

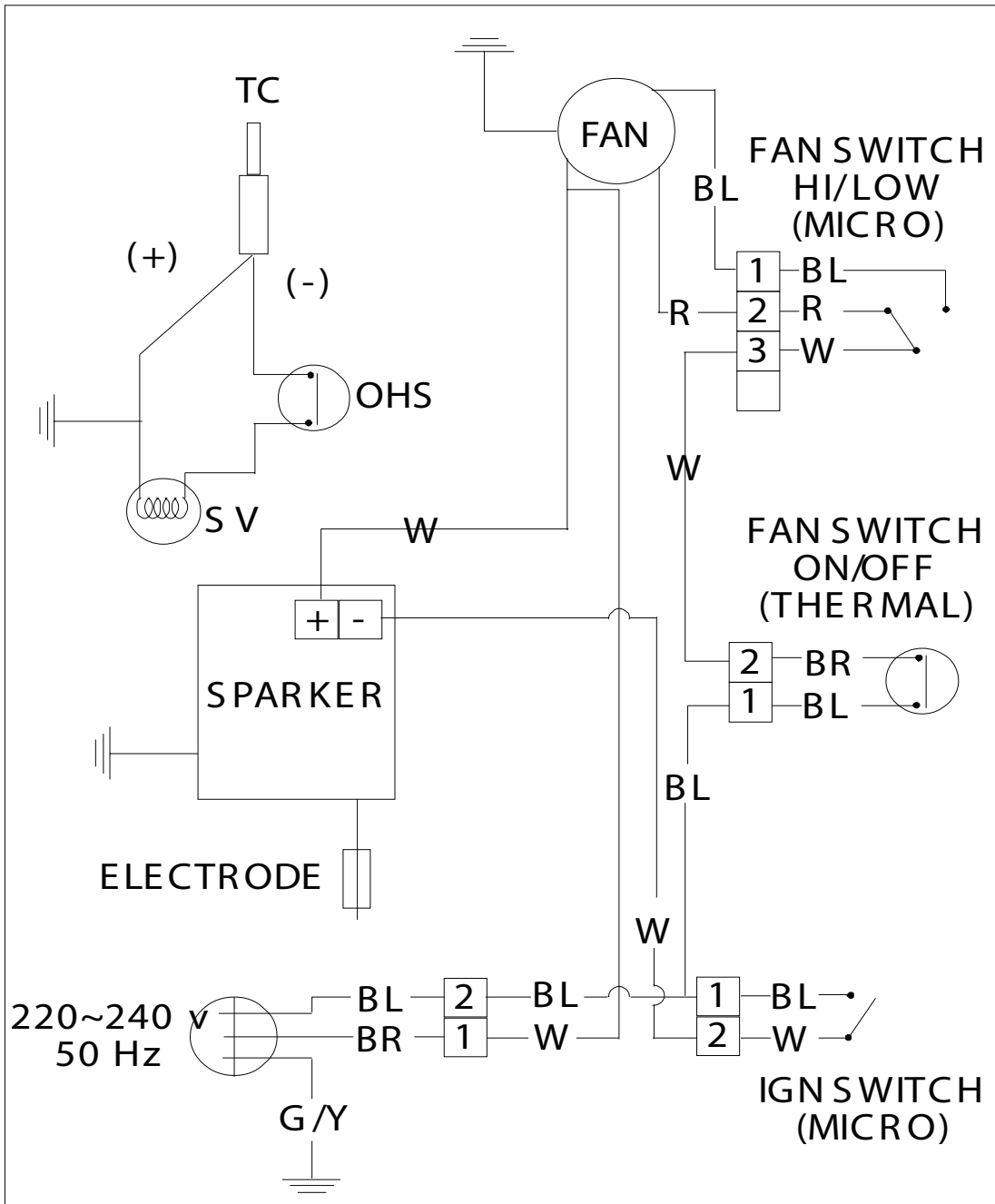

- R Red
- BL Blue
- BR Brown
- W White
- G/Y Green/Yellow

- OHS Overheat Switch
- SV Solenoid Valve
- TC Thermocouple

# Appendix 1

## Zero clearance installation overview

We have this final installation image available for a zero clearance installation. It is intended to provide an overview of how all the components are fitted together and to illustrate important installation points.

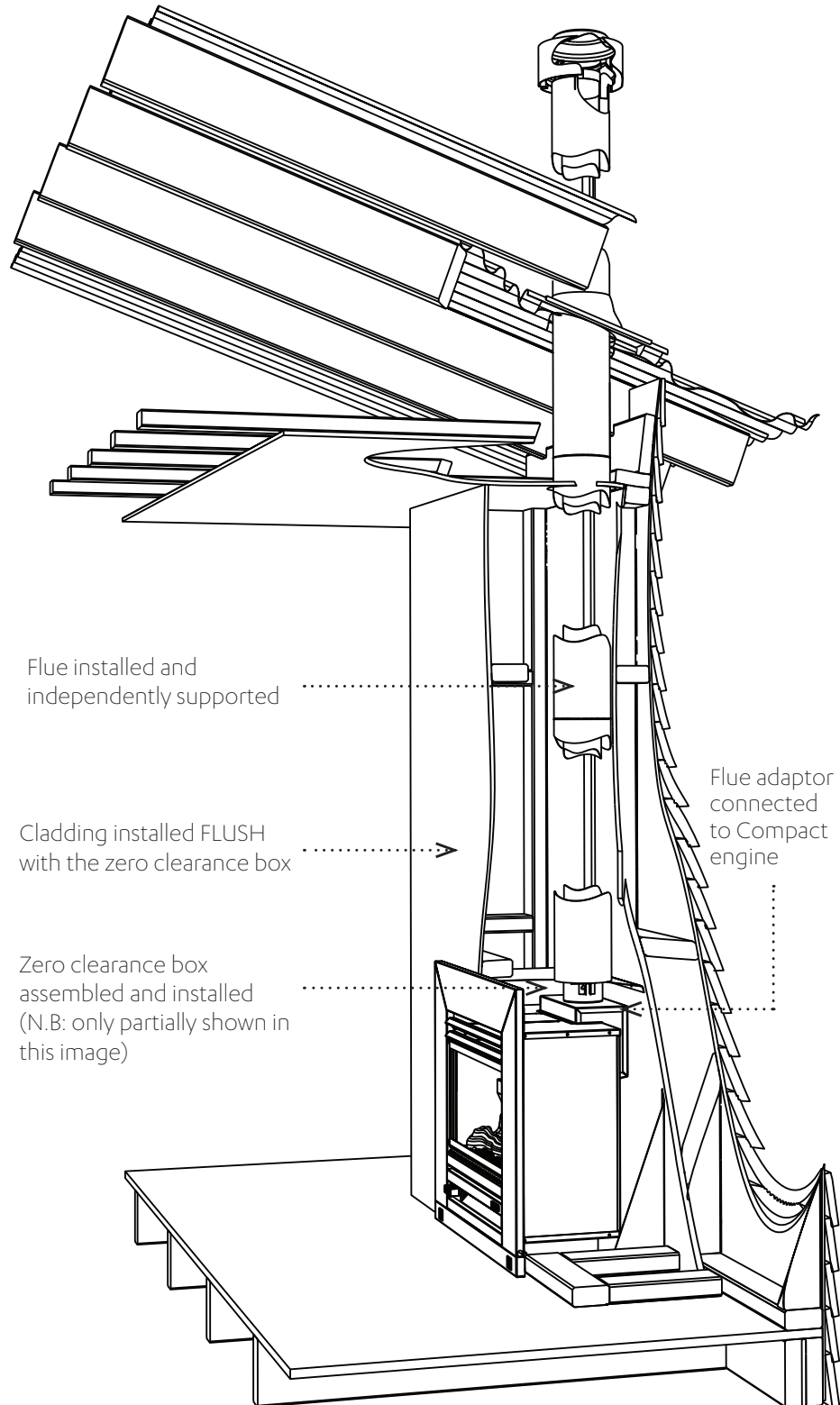



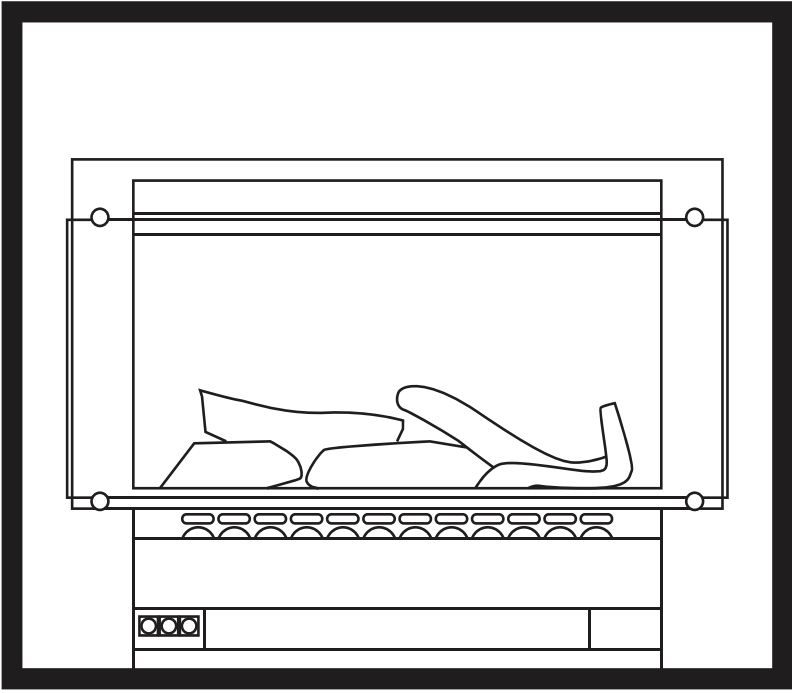

Experience our innovation

**Rinnai.co.nz** | **0800 746 624**

<http://www.youtube.com/rinnainz>